

# **6VA+**

## **USER'S MANUAL**

1. **System power on by PS/2 Mouse:** First, enable this function in CMOS Setup, then you can power on the system by double clicking the right or left button of your PS/2 Mouse.
2. **System power on by Keyboard:** If your ATX power supply supports larger than 300 mA 5V Stand-By current, you can power on your system by entering password from the Keyboard after setting the “Keyboard power on” jumper and password in CMOS Setup.
3. **Support Modem Ring-On.** (Include internal Modem and external modem on COM A and COM B)
4. **Wake-up on LAN supports:** Your ATX power supply must support larger than 720 mA 5V Stand-By current.
5. **Support 3 steps ACPI LED.**

**Pentium® III/Celeron™ Processor Motherboard**

**REV. 1.0 First Edition**

R-10-01-000405



The author assumes no responsibility for any errors or omissions which may appear in this document nor does it make a commitment to update the information contained herein.

Third-party brands and names are the property of their respective owners.

Sound Blaster is a registered trademark of Creative Technology Ltd in the United States and certain other countries. Sound Blaster-LINK and SB-LINK are trademarks of Creative Technology Ltd.

Apr. 5, 2000 Taipei, Taiwan

## I. Quick Installation Guide :

### CPU SPEED SETUP

The system bus frequency can be switched at 66MHz, 100MHz and 133MHz by adjusting DIP SW1. The CPU frequency ratio can be switched from X3 to X9.5 by adjusting DIP SW2. The user can set up CPU speed for 300-866MHz processors by adjusting SW1 and SW2 properly.

⚠️**The CPU speed must match with the frequency RATIO. It will cause system hanging up if the frequency RATIO is higher than CPU's.**

#### Set System Bus Speed

##### SW 1 :

CPU	6	5	4	3	2	1	PCI
AUTO	O	O	X	X	X	X	33.3
66	X	X	X	X	O	O	33.3
75	X	X	X	O	O	O	37.5
83	X	X	O	X	O	O	41.6
100	X	X	X	X	X	O	33.3
112	X	X	X	O	X	O	37.5
124	X	X	O	X	X	X	31
133	X	X	X	X	X	X	33.3
140	X	X	O	O	X	X	37.5
150	X	X	X	O	X	X	35

★**Note: Please set the CPU host frequency in accordance with your processor's specifications. We don't recommend you to set the system bus frequency over the CPU's specification because these specific bus frequencies are not the standard specifications for CPU, chipset and most of the peripherals. Whether your system can run under these specific bus frequencies properly will depend on your hardware configurations, including CPU, Chipsets, SDRAM, Cards....etc.**

**SW2: (O:ON / X:OFF)**

FREQ. RATIO	DIP SWITCH (SW2)			
	4	3	2	1
X 3	O	O	X	O
X 3.5	O	O	X	X
X 4	O	X	O	O
X 4.5	O	X	O	X
X 5	O	X	X	O
X 5.5	O	X	X	X
X 6	X	O	O	O
X 6.5	X	O	O	X
X 7	O	X	O	X
X 7.5	X	O	X	X
X 8	X	X	O	O
X 8.5	X	X	O	X
X 9	X	X	X	O
X 9.5	X	X	X	X

☛ For Auto Jumper setting:

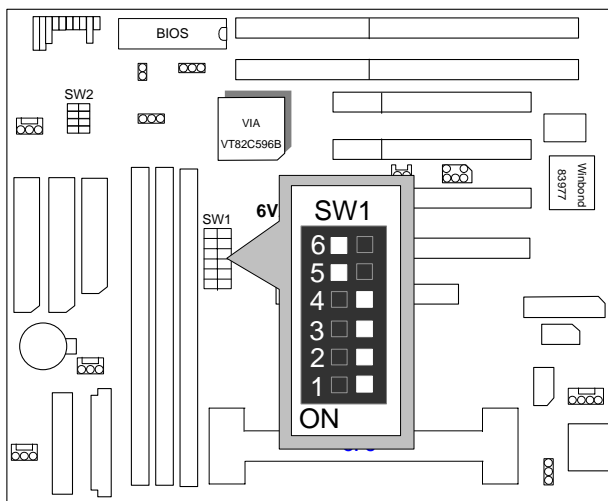

★Note: If you use 66, 100, 133 MHz CPU, we recommend you to set up your system speed to "Auto" value.

1. Celeron™ 300A / 66MHz FSB

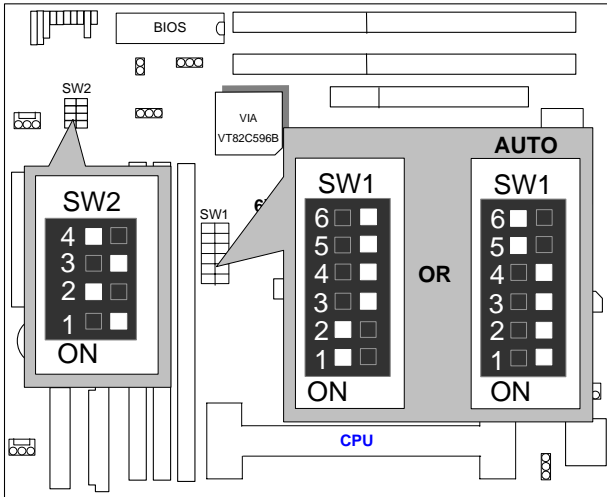

2. Celeron™ 333 / 66MHz FSB

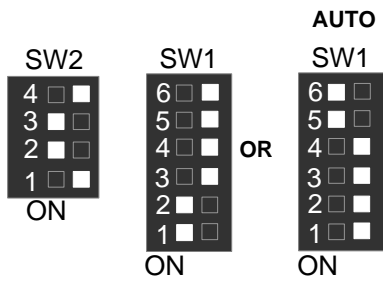

3. Celeron™ 366 / 66MHz FSB

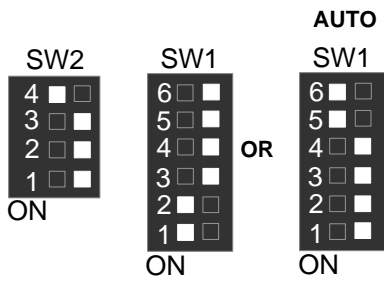

4. Celeron™ 400 / 66MHz FSB

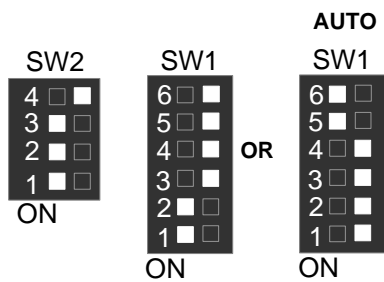

5. Celeron™ 433 / 66MHz FSB

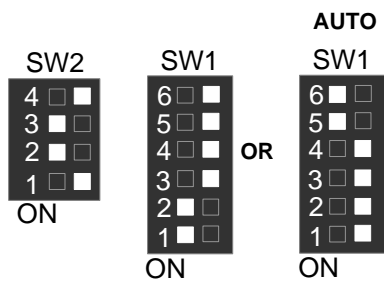

6. Celeron™ 466 / 66 MHz FSB

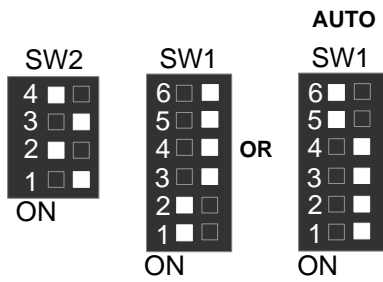

7. Celeron™ 500 / 66 MHz FSB

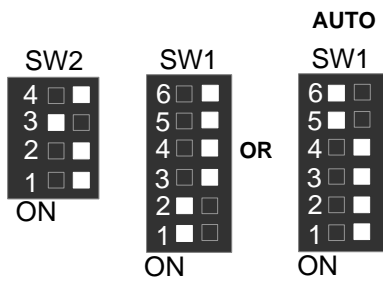

8. Celeron™ 533 / 66 MHz FSB

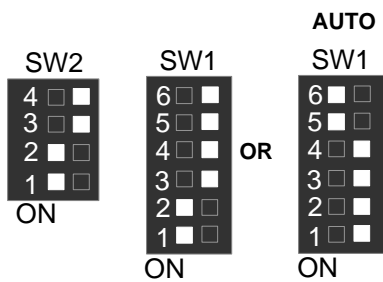



9. Celeron™ 566 / 66 MHz FSB

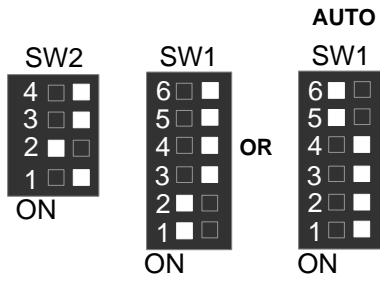

10. Cyrix Joshua 300 / 100 MHz FSB

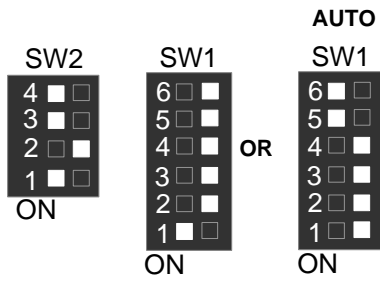

11. Pentium® !!! 500 / 100MHz FSB

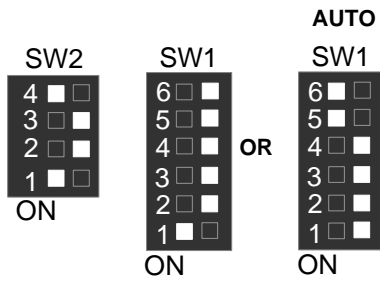

12. Pentium® !!! 550 / 100MHz FSB

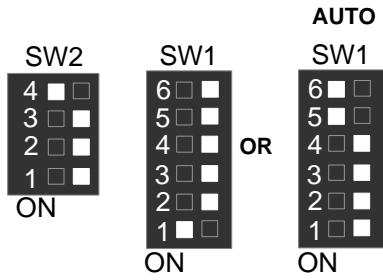

13. Pentium® !!! 600 / 100MHz FSB

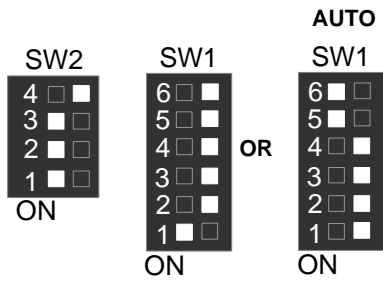

14. Pentium® !!! 650 / 100MHz FSB

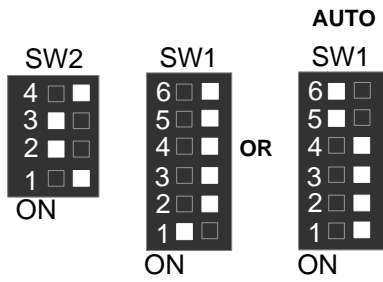

15. Pentium® !!! 700 / 100MHz FSB

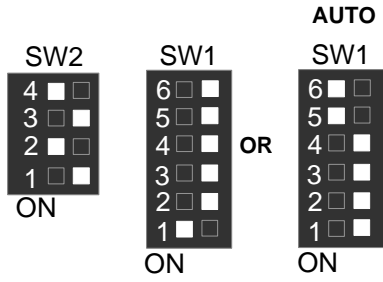

16. Pentium® !!! 750 / 100MHz FSB

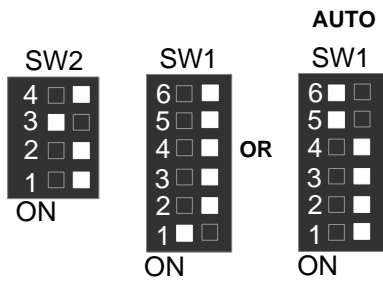

17. Pentium® !!! 800 / 100MHz FSB

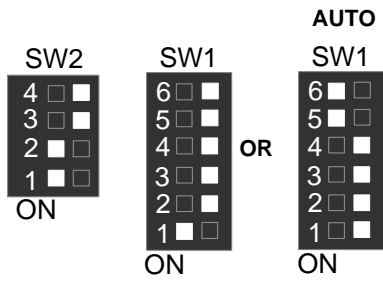

18. Pentium® !!! 850 / 100MHz FSB

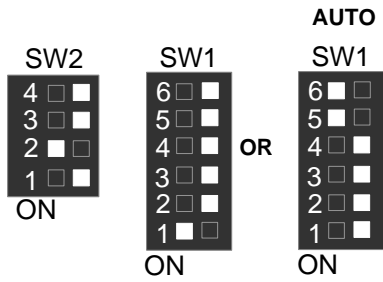

18. Pentium® !!! 533 / 133MHz FSB

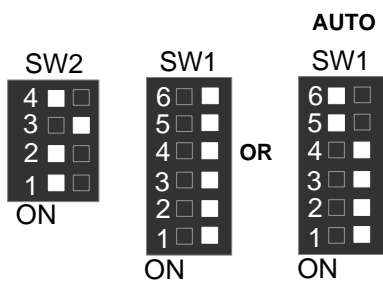

19. Pentium® !!! 600 / 133MHz FSB

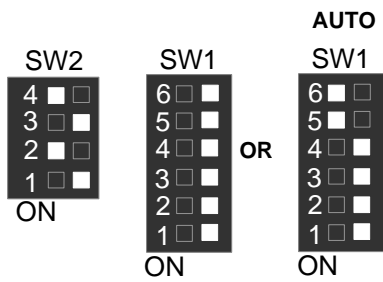

20. Pentium® !!! 667 / 133MHz FSB

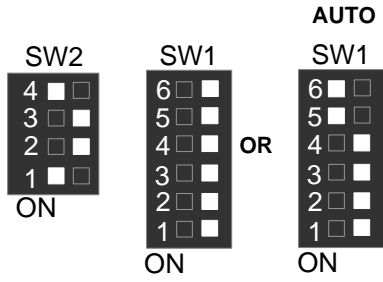

21. Pentium® !!! 733 / 133MHz FSB

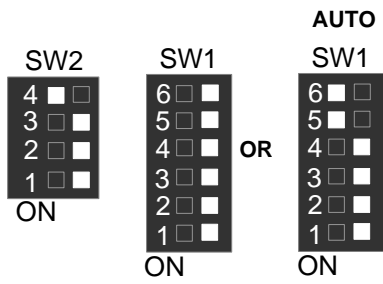

22. Pentium® !!! 800 / 133MHz FSB

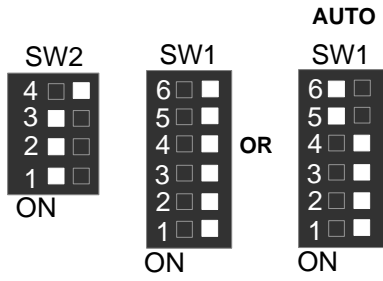

23. Pentium® !!! 866 / 133MHz FSB

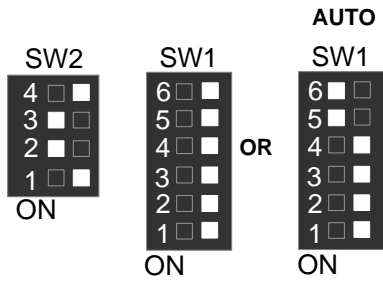

**II. Jumper setting :**

IR : Infrared Connector (Optional)

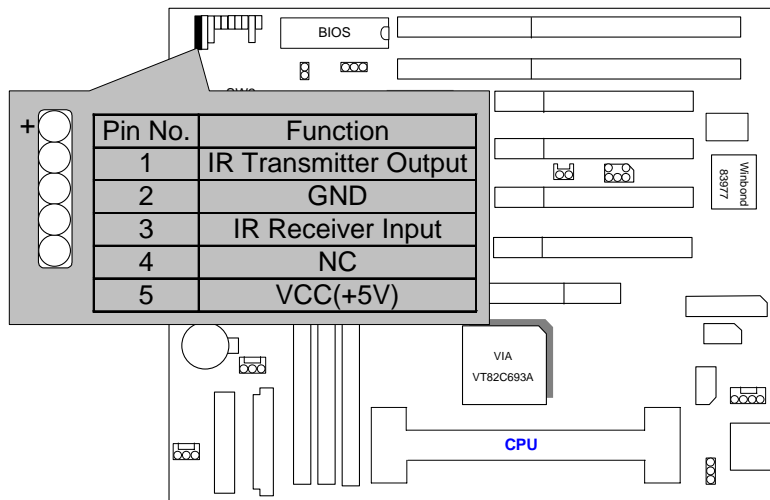

PWR : Power LED Connector

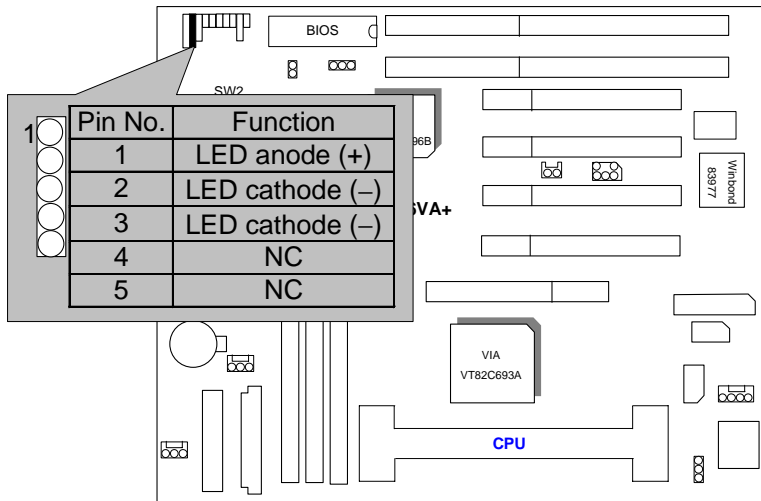

SPK : Speaker Connector

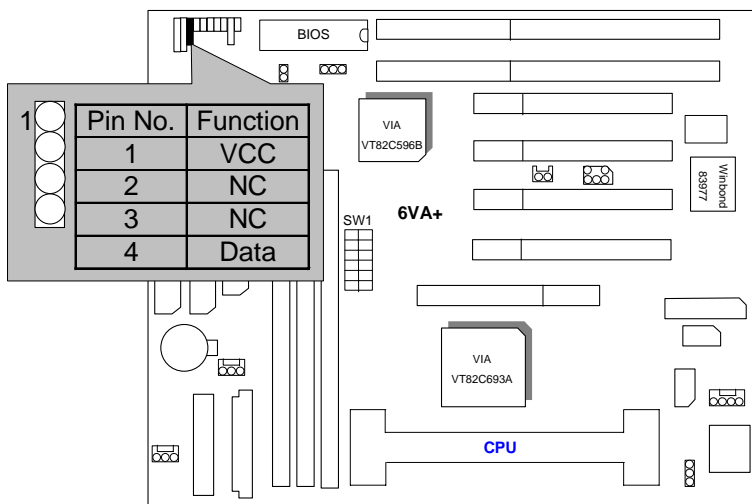

**TD : Turbo LED Connector**

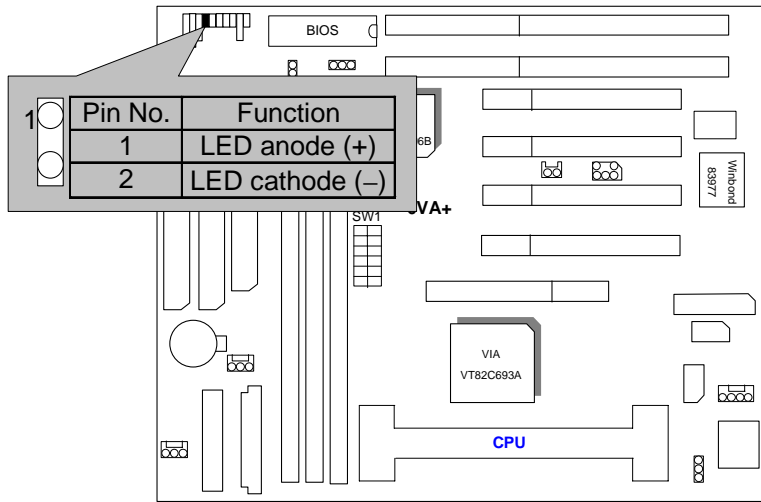

**TB : Turbo Switch Connector**

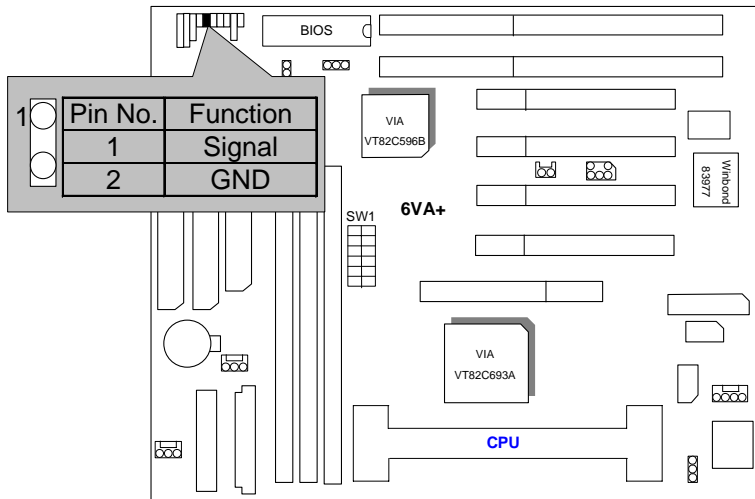



RST : Reset Switch

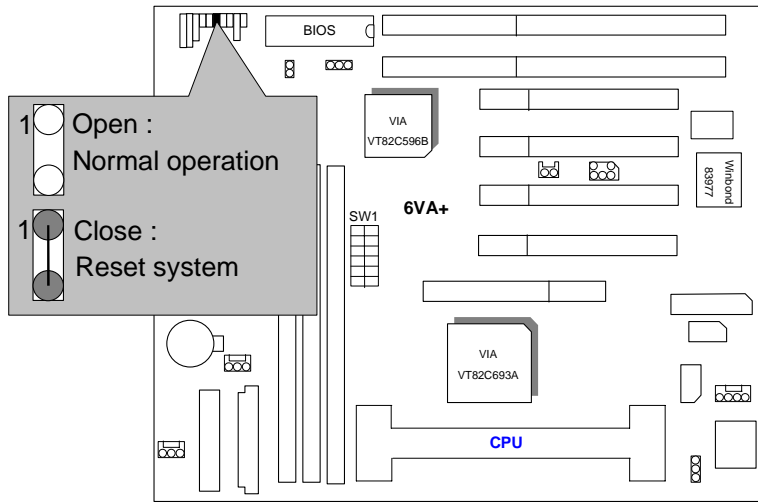

GD : Green Function LED

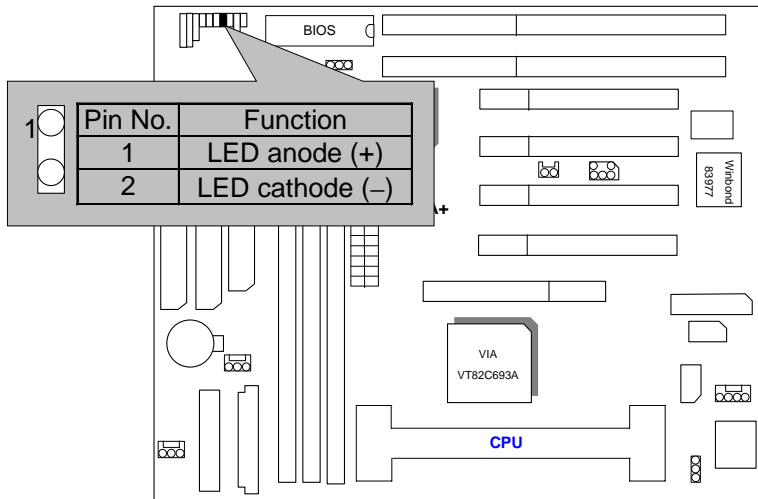

GN : Green Function Switch

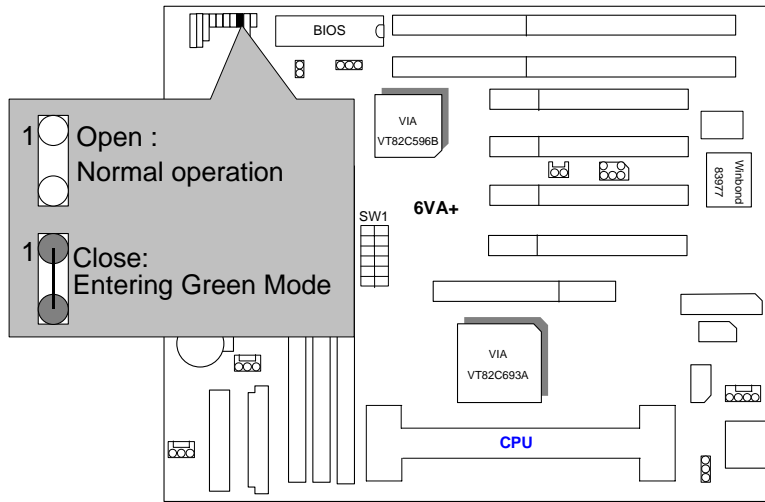

HD : IDE Hard Disk Active LED

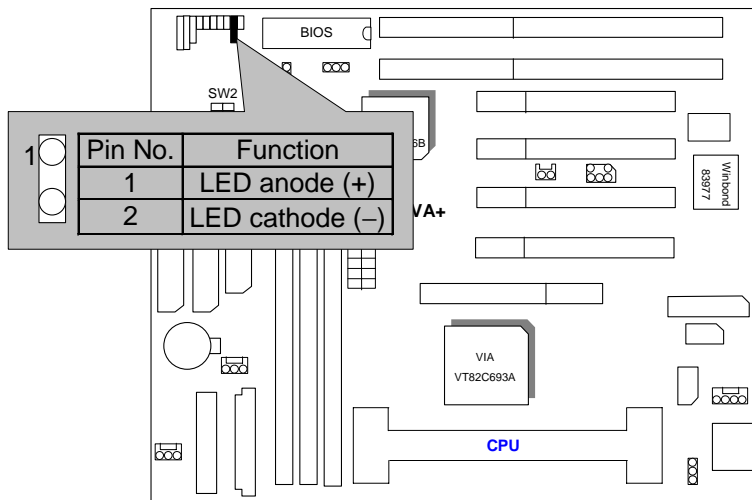

Soft PWR : Soft Power Connector

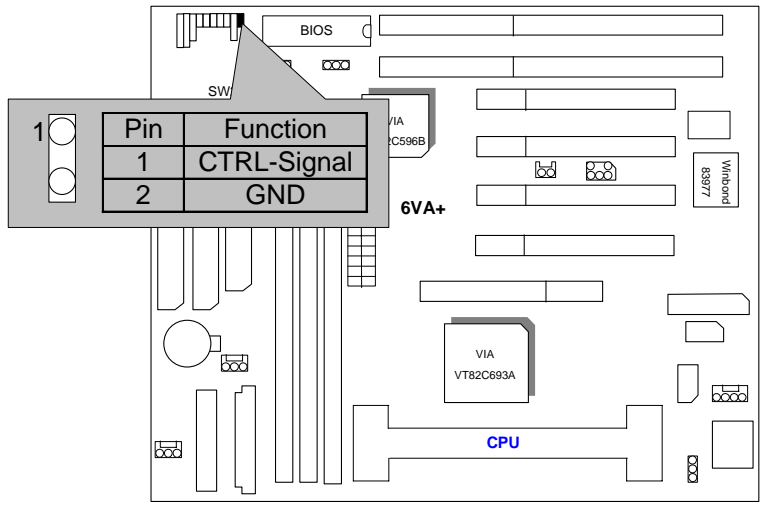

POWER : P8&P9 Power Connector

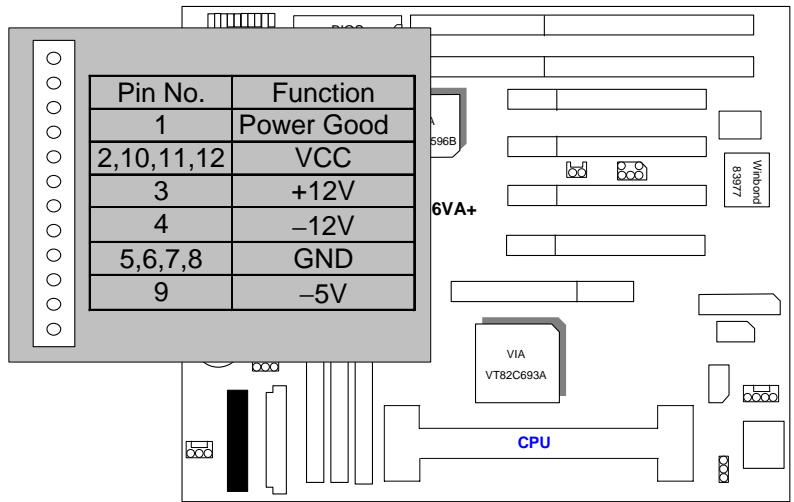

ATX Power : ATX Power Connector

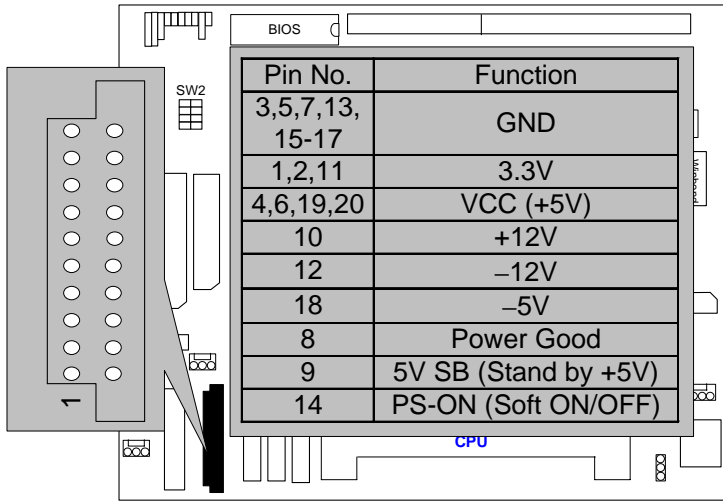

CPU FAN : CPU Cooling Fan Power Connector

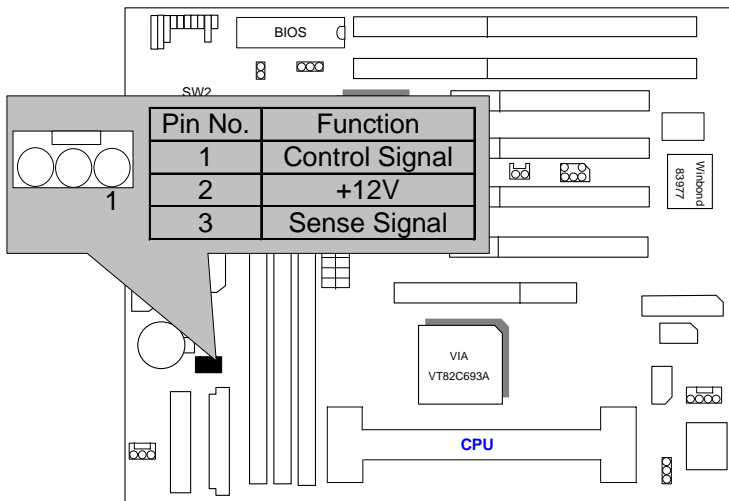

System FAN : System Cooling Fan Power Connector

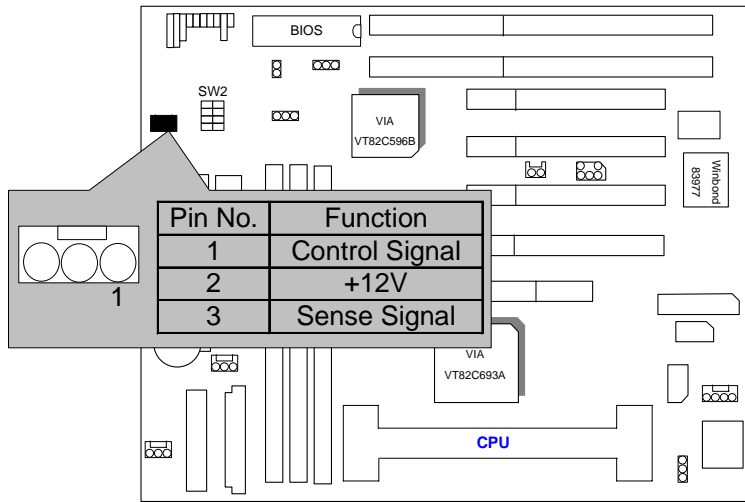

Power FAN : Power Cooling Fan Power Connector

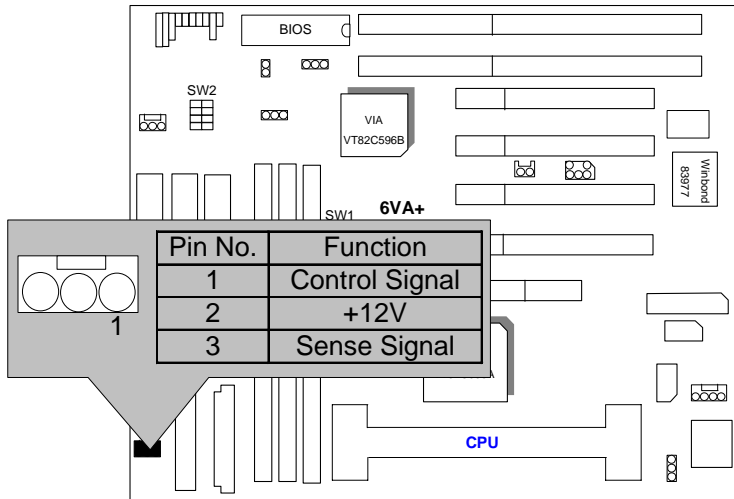

IDE1: Primary IDE port

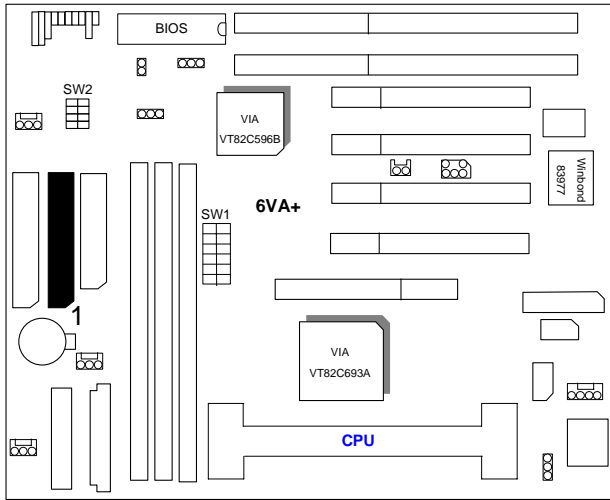

IDE2: Secondary IDE port

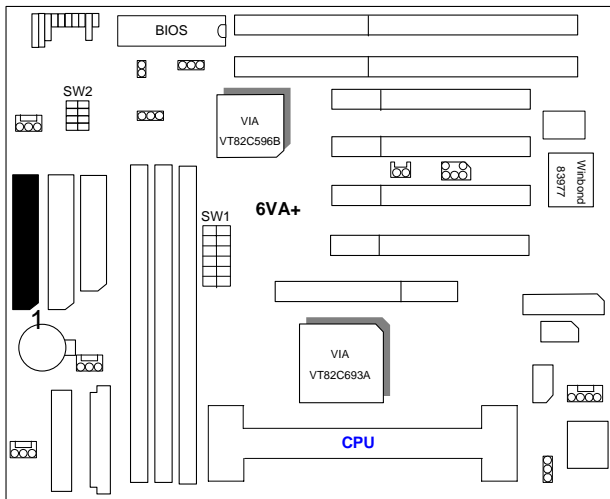

Floppy : Floppy Port

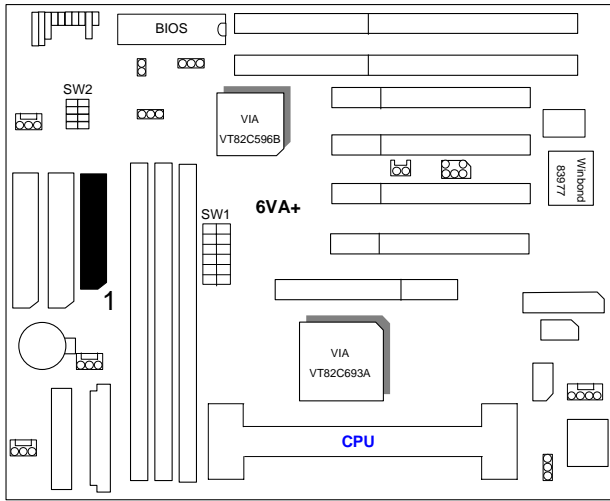

LPT : LPT Port

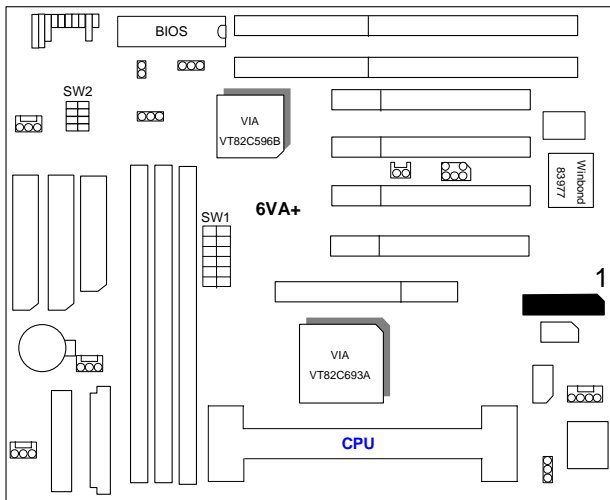

COMB : COMB Port

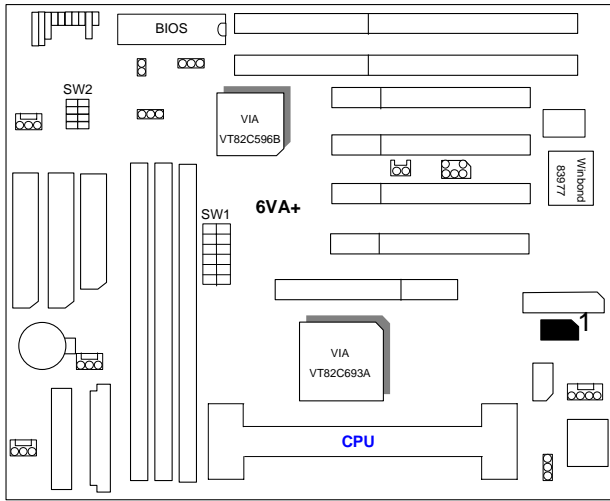

COMA : COMA Port

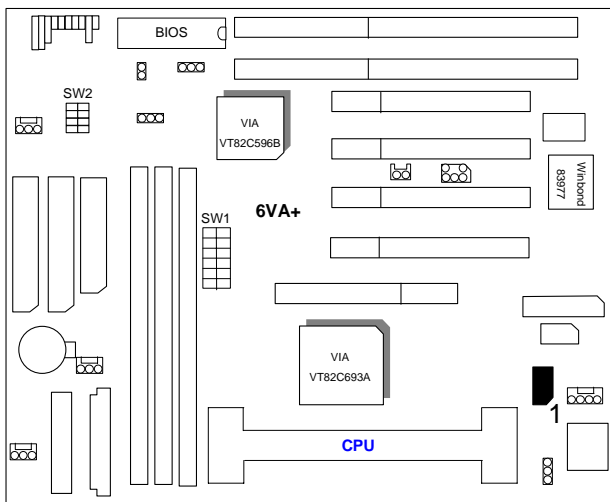



JP1 : Keyboard Power On (for ATX Power Supply only)

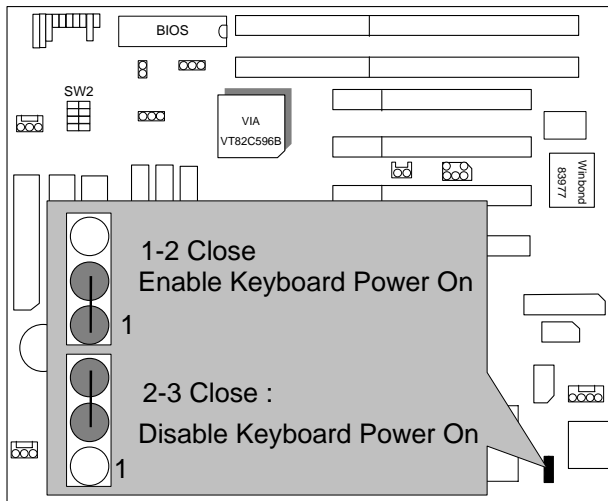

K.B : Keyboard Connector

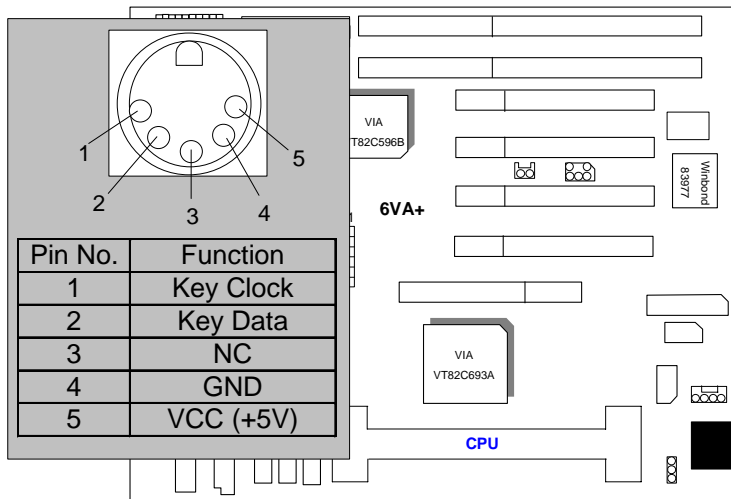

JP4 : PS/2 MOUSE

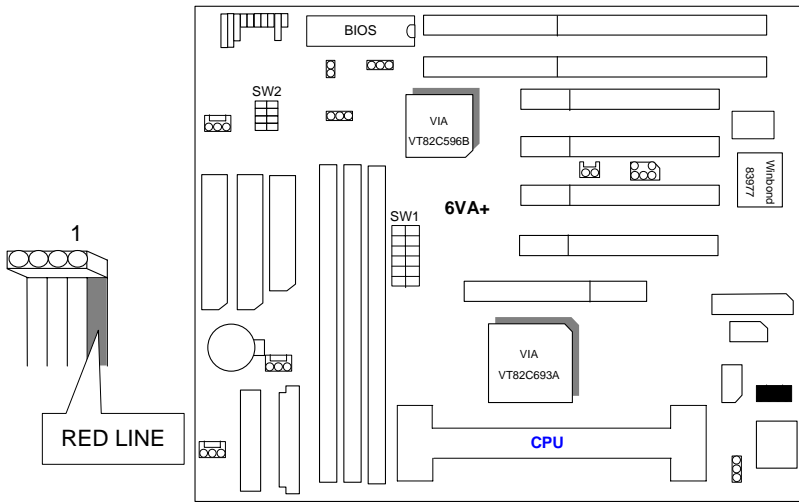

USB : USB Port

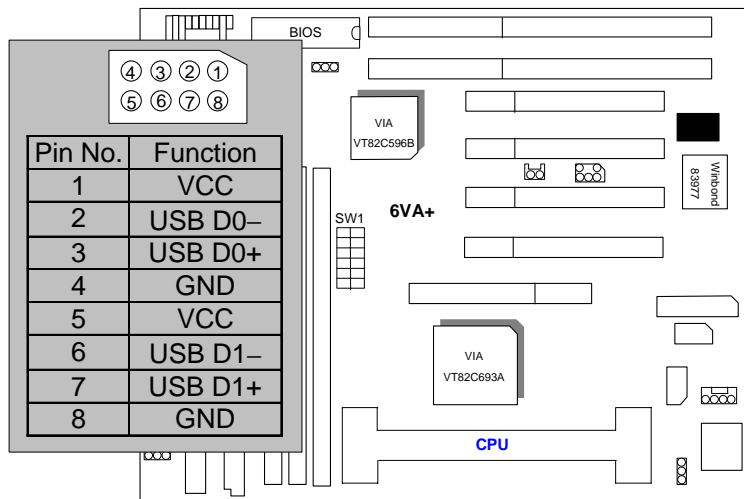

J11 : Wake on LAN (for ATX Power Supply only)

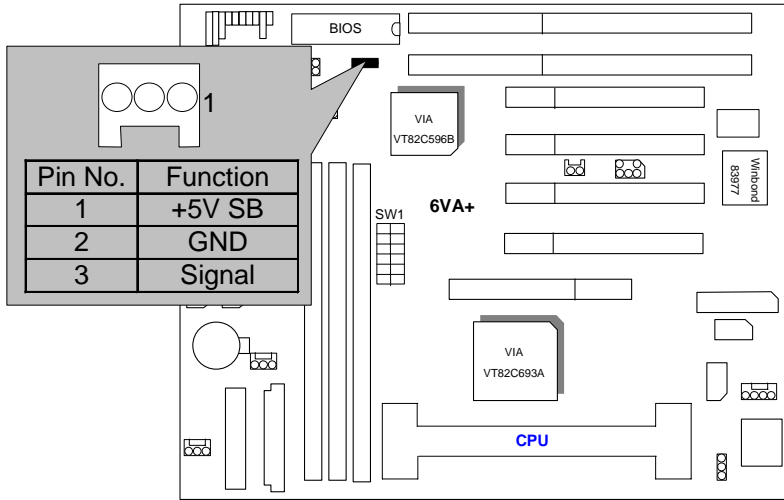

JP9 : Clear CMOS

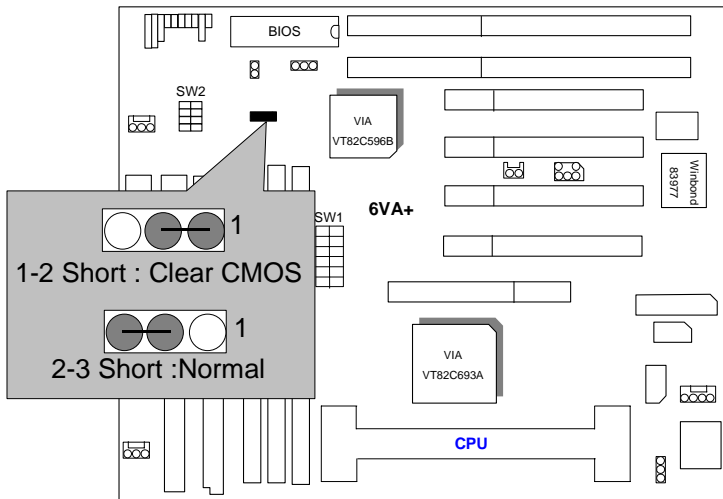

JP10 : Case Open (Optional)

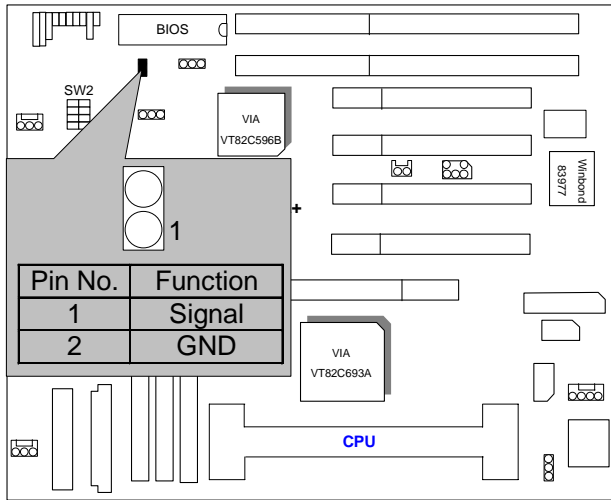

JP19 : Internal Modem Card Ring PWR On

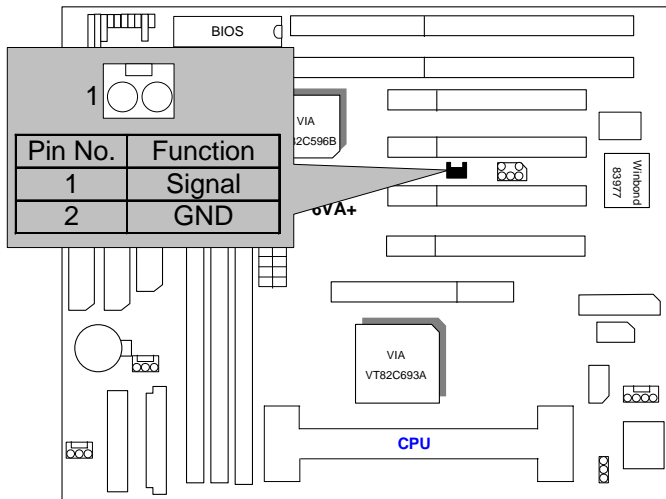

SB-LINK : For PCI Audio / Sound Card use only (Optional)  
 (Creative PCI Sound Card Support)

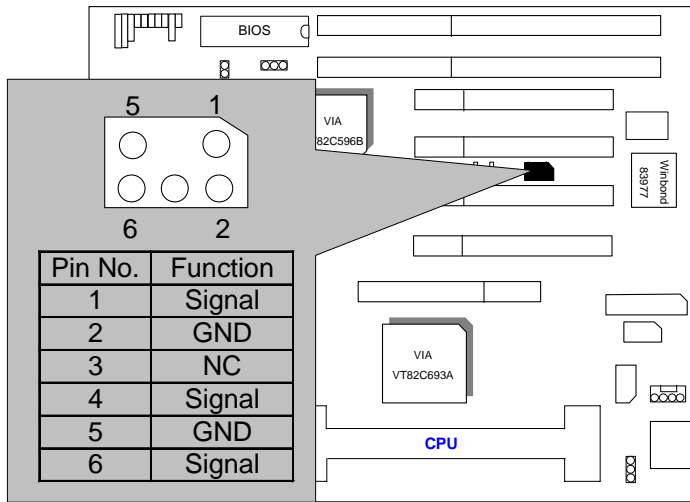

BAT1 : For Battery

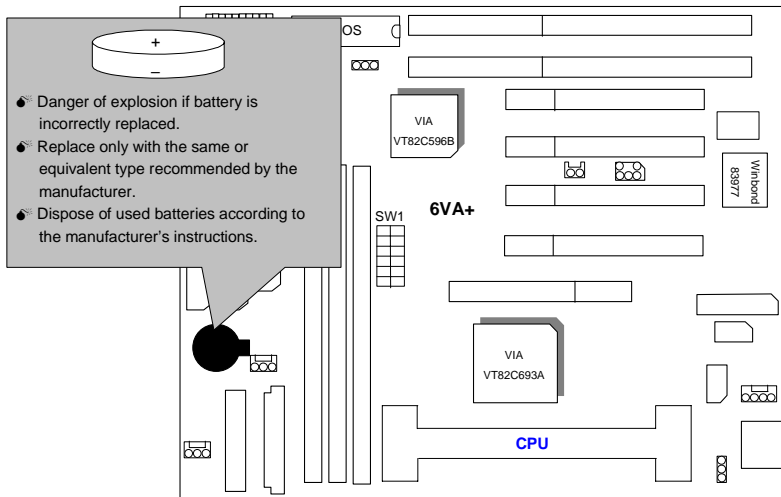

### III. Top Performance Test Setting:

These data are just referred by users, and there is no responsibility for different testing data values gotten by users. (The different Hardware & Software configuration will result in different benchmark testing results.)

- CPU Pentium® !!! 800 processor
- DRAM (128x3)MB SDRAM (NEC D4564841G5-A75)
- CACHE SIZE 256 KB included in CPU
- DISPLAY GA-GF2560 AGP Display Card (32MB SGRAM)
- STORAGE Onboard IDE (QUANTUM KA13600AT)
- O.S. Windows™ NT 4.0 SPK6
- DRIVER Display Driver at 1024 x 768 x 64k colors x 75Hz.  
TUCD 1.4

Processor	Intel Pentium®!!!
	800MHz (133x6)
<b>Winbench99</b>	
CPU mark 99	64.9
FPU Winmark 99	4240
Business Disk Winmark 99	5520
Hi-End Disk Winmark 99	12100
Business Graphics Winmark 99	326
Hi-End Graphics Winmark 99	677
<b>Winstone99</b>	
Business Winstone99	40.2
Hi-End Winstone99	42.2

**TABLE OF CONTENTS**

**1. INTRODUCTION**

1.1. PREFACE ..... 1-1  
1.2. KEY FEATURES ..... 1-1  
1.3. PERFORMANCE LIST ..... 1-2  
1.4. BLOCK DIAGRAM..... 1-3  
1.5. INTRODUCE THE Pentium® II/III Processor ..... 1-4  
1.6. What is AGP? ..... 1-5

**2. SPECIFICATION**

2.1. HARDWARE ..... 2-1  
2.2. SOFTWARE ..... 2-2  
2.3. ENVIRONMENT ..... 2-2

**3. HARDWARE INSTALLATION**

3.1. UNPACKING ..... 3-1  
3.2. MAINBOARD LAYOUT..... 3-2  
3.3. QUICK REFERENCE FOR JUMPERS & CONNECTORS..... 3-2  
3.4. DRAM INSTALLATION..... 3-5  
3.5. CPU SPEED SETUP ..... 3-6  
3.6. CMOS RTC & ISA CFG CMOS SRAM ..... 3-7  
3.7. SPEAKER CONNECTOR INSTALLATION..... 3-7  
3.8. HARDWARE RESET SWITCH CONNECTOR INSTALLATION..... 3-7  
3.9. POWER LED CONNECTOR INSTALLATION ..... 3-7  
3.10. IDE & ATAPI DEVICE INSTALLATION ..... 3-7  
3.11. PERIPHERAL DEVICE INSTALLATION..... 3-8  
3.12. KEYBOARD & PS/2 MOUSE INSTALLATION ..... 3-8

**4. BIOS CONFIGURATION**

4.1. ENTERING SETUP ..... 4-1

4.2. CONTROL KEYS ..... 4-1

4.3. GETTING HELP ..... 4-2

    4.3.1. Main Menu ..... 4-2

    4.3.2. Status Page Setup Menu / Option Page Setup Menu ..... 4-2

4.4. THE MAIN MENU ..... 4-2

4.5. STANDARD CMOS SETUP MENU ..... 4-4

4.6. BIOS FEATURES SETUP ..... 4-8

4.7. CHIPSET FEATURES SETUP ..... 4-12

4.8. POWER MANAGEMENT SETUP ..... 4-14

4.9. PNP/PCI CONFIGURATION ..... 4-18

4.10. LOAD BIOS DEFAULTS ..... 4-20

4.11. LOAD PERFORMANCE DEFAULTS ..... 4-21

4.12. INTEGRATED PERIPHERALS ..... 4-22

4.13. SUPERVISOR / USER PASSWORD ..... 4-26

4.14. IDE HDD AUTO DETECTION ..... 4-27

4.15. SAVE & EXIT SETUP ..... 4-28

4.16. EXIT WITHOUT SAVING ..... 4-29

**Appendix A: VIA Chipset Driver installation ..... A-1**

**Appendix B: Bugs & Limitations ..... B-1**

**Appendix C: BIOS Flash Procedure ..... C-1**



## 1. INTRODUCTION

### 1.1. PREFACE

Welcome to use the **6VA+** motherboard. It is a Intel® (Celeron™, Pentium® !!!) and Cyrix Joshua Slot 1 Processor based PC / AT compatible system with AGP / PCI / ISA Bus, and has been designed to be the fastest PC / AT system. There are some new features allow you to operate the system with just the performance you want.

This manual also explains how to install the motherboard for operation, and how to set up your CMOS CONFIGURATION with BIOS SETUP program.

### 1.2. KEY FEATURES

- ❑ Intel Pentium® II!!!!/Celeron Processor based PC / AT compatible main board.
- ❑ Slot 1 supports Pentium® II!!!!/Celeron processor running at 300-866 MHz.
- ❑ VIA Apollo series chipset, Supports AGP/SDRAM/Ultra DMA33/ATA66 IDE/ Keyboard and PS/2 Mouse Power On / ACPI features.
- ❑ Supports 3xDIMMs using 3.3V EDO/SDRAM DIMM module.
- ❑ Supports 16MB~1.5GB (256Mb DRAM technology) SDRAM memory on board.
- ❑ Supports ECC or Non-ECC type DRAM module.
- ❑ 1xAGP slot, 4xPCI Bus slots, 2xISA Bus slots.
- ❑ Supports 2 channels Ultra DMA 33/ATA 66 EIDE ports for 4 IDE Devices.
- ❑ Supports 2xCOM (16550), 1xLPT, 1x1.44MB Floppy port.
- ❑ Supports USB port & PS/2 Mouse port.
- ❑ Licensed AWARD BIOS, 2M bits FLASH ROM.
- ❑ 25.4 cm x 22.2 cm BABY AT SIZE form factor, 4 layers PCB.

### 1.3. PERFORMANCE LIST

The following performance data list is the testing results of some popular benchmark testing programs.

These data are just referred by users, and there is no responsibility for different testing data values gotten by users. (The different Hardware & Software configuration will result in different benchmark testing results.)

- CPU Pentium® !!! 800 processor
- DRAM (128x3)MB SDRAM (NEC D4564841G5-A75)
- CACHE SIZE 256 KB included in CPU
- DISPLAY GA-GF2560 AGP Display Card (32MB SGRAM)
- STORAGE Onboard IDE (QUANTUM KA13600AT)
- O.S. Windows™ NT 4.0 SPK6
- DRIVER Display Driver at 1024 x 768 x 64k colors x 75Hz.  
TUCD 1.4

Processor	Intel Pentium®!!! 800MHz (133x6)
<b>Winbench99</b>	
CPU mark 99	64.9
FPU Winmark 99	4240
Business Disk Winmark 99	5520
Hi-End Disk Winmark 99	12100
Business Graphics Winmark 99	326
Hi-End Graphics Winmark 99	677
<b>Winstone99</b>	
Business Winstone99	40.2
Hi-End Winstone99	42.2

### 1.4. BLOCK DIAGRAM

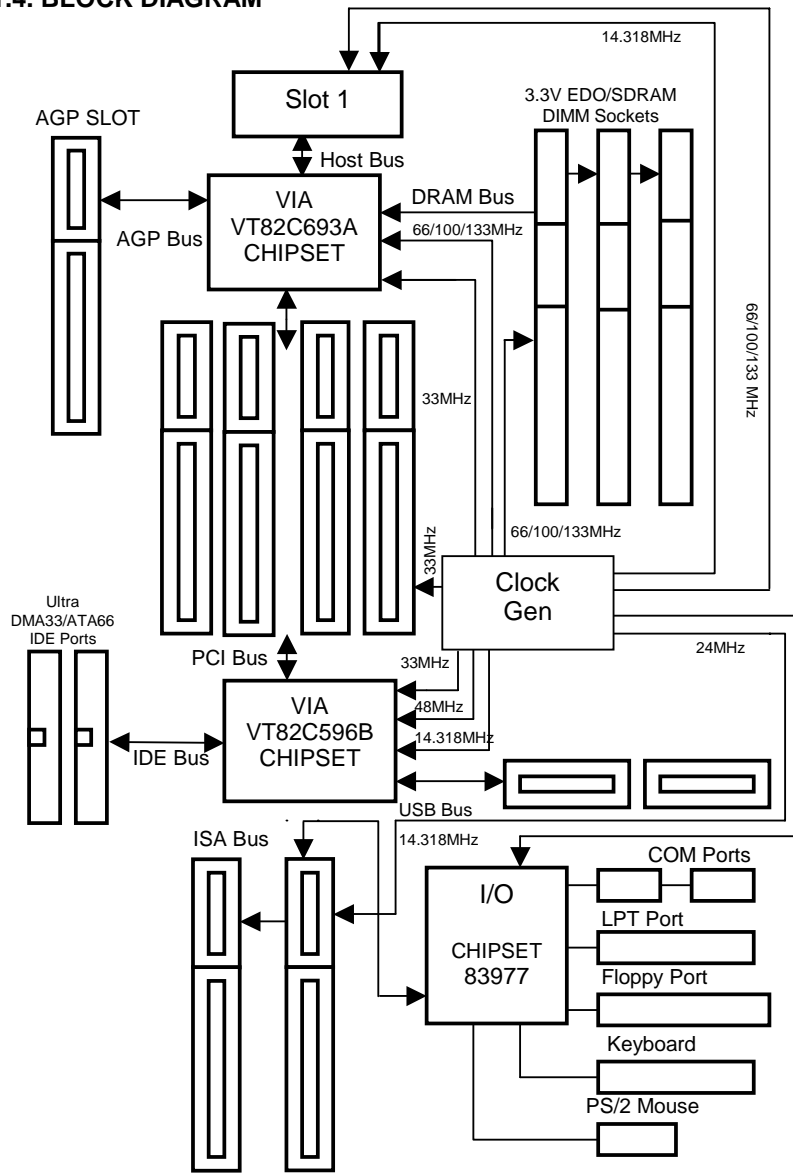

### 1.5. INTRODUCE THE Pentium® II / !!! Processors

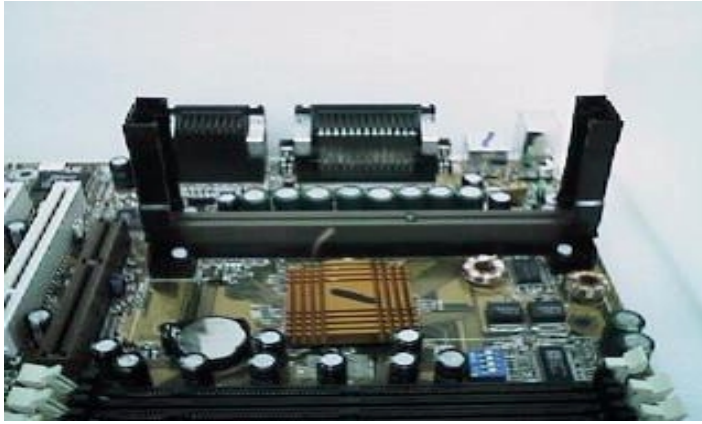

Figure 1: Universal Retention Mechanism & attach Mount



Figure 2: OEM Pentium® II Processor



Figure 3: OEM Pentium® III Processor

### 1.6 What is AGP?

The Accelerated Graphics Port (AGP) is a new port on the Host-To-PCI bridge device that supports an AGP port. The main purpose of the AGP port is to provide fast access to system memory.

The AGP port can be used either as fast PCI port (32-bits at 66MHz vs. 32-bits at 33MHz) or as an AGP port which supports 2x data-rate, a read queue, and side band addressing. When the 2x-data rate is used the port can transmit data at 533MB/sec ( $66.6 \times 2 \times 4$ ). The read-queue can be used to pipeline reads – removing the effects of the reads-latency. Side band addressing can be used to transmit the data address on a separate line in order to speed up the transaction.



## 2. SPECIFICATION

### 2.1. HARDWARE

- CPU
  - Pentium® II / !!! / Celeron processor 300 – 866 MHz.
  - 242 pins 66 / 100 / 133MHz slot1 on board.
  - Supports 16MB ~ 1.5GB (256Mb technology) SDRAM.
  - 66/100/133 MHz system speed.
- CHIPSET
  - VT82C693A PCI/AGP Controller (PAC)
  - VT82C596B PCI ISA IDE Controller.
- SPEED
  - 66 MHz AGP bus speed. (133MHz 2xmode)
  - 33 MHz PCI-Bus speed.
  - 8 MHz AT bus speed.
- CLOCK GENERATOR
  - Supports 60/75/83/100/133/150MHz
- DRAM MEMORY
  - 3 banks 168 pins DIMM module sockets on board.
  - Use 16 / 32 / 64 / 128 / 256 / 512 MB(256Mb technology) DIMM module DRAM.
  - Supports 3.3V EDO/SDRAM.
  - Supports ECC or Non-ECC type DRAM.
- CACHE MEMORY
  - 32 KB L1 cache memory included in CPU.
  - 128/256KB L2 cache memory included in CPU.
  - Supports DIB speed mode for L2 Cache.
- I/O BUS SLOTS
  - 4 33MHz Master / Slave PCI-BUS.
  - 2 8MHz 16 bits ISA BUS.
  - 1 66MHz / 133MHz AGP bus.
- IDE PORTS
  - 2 Ultra DMA33/ATA66 Bus Master IDE channels on board.(Using IRQ14,15)
  - Support Mode 3,4 IDE & ATAPI CD – ROM.

- I/O PORTS
  - Supports 2 16550 COM ports.
  - Supports 1 EPP/ECP LPT port.
  - Supports 1 1.44 / 2.88 MB Floppy port.
  - Supports 2 USB ports.
  - Supports PS/2 Mouse & PS/2 Keyboard.
- GREEN FUNCTION
  - Suspend mode support.
  - Green switch & ACPI LED support.
  - IDE & Display power down support.
  - Monitor all IRQ / DMA / Display / I/O events.
- BIOS
  - 2M bits FLASH ROM.
  - Supports Plug & Play, DMI Function.
- DIMENSION
  - BABY AT Form Factor, 4 layers PCB.

## 2.2. SOFTWARE

- DRIVER
  - TUCD
- BIOS
  - Licensed AWARD BIOS.
  - AT CMOS Setup, BIOS / Chipset Setup, Green Setup, Hard Disk Utility included.
- O.S.
  - Operation with MS-DOS®, Windows®95, Windows®98, WINDOWS™ NT, OS/2, NOVELL and SCO UNIX.

## 2.3. ENVIRONMENT

- Ambient Temp.
  - 0°C to +50°C (Operating).
- Relative Hum.
  - 0 to +85% (Operating).
- Altitude
  - 0 to 10,000 feet (Operating).
- Vibration
  - 0 to 1,000 Hz.
- Electricity
  - 4.9 V to 5.2 V. (Max. 20A current at 5V.)



### 3. HARDWARE INSTALLATION

#### 3.1. UNPACKING

The main board package should contain the following:

- The **6VA+** main board.
- USER'S MANUAL for main board.
- Cable set for IDE, Floppy & I/O devices.
- CD for main board Utilities.

The main board contains sensitive electric components, which can be easily damaged by static electricity, so the main board should be left in its original packing until it is installed.

Unpacking and installation should be done on a grounded anti-static mat. The operator should be wearing an anti static wristband, grounded at the same point as the anti-static mat.

Inspect the main board carton for obvious damage. Shipping and handling may cause damage to your board. Be sure there are no shipping and handling damages on the board before proceeding.

After opening the main board carton, extract the system board and place it only on a grounded anti-static surface component side up. Again inspect the board for damage. Press down on all of the socket IC's to make sure that they are properly seated. Do this only on with the board placed on a firm flat surface.

**⚠ DO NOT APPLY POWER TO THE BOARD IF IT HAS BEEN DAMAGED.**

### 3.2. MAINBOARD LAYOUT

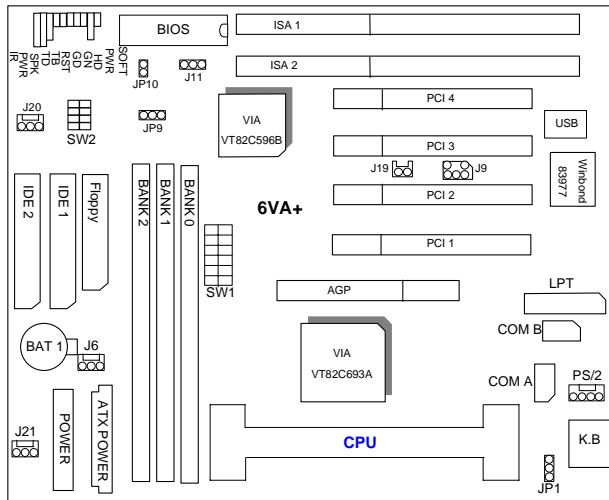

<Figure 3.1>

### 3.3. QUICK REFERENCE FOR JUMPERS & CONNECTORS

◆ I/O Ports Connector	
USB	USB port.
IDE1	For Primary IDE port.
IDE2	For Secondary IDE port.
KB	For Keyboard port.
PS/2	For PS/2 Mouse port.
Floppy	For Floppy port
COMB	For Serial port2 (COM B).
COMA	For Serial port1 (COM A).
Power	For AT Power Connector.
ATX Power	For ATX Power Connector.
LPT	For LPT port.
◆ CPU	
For Celeron™ , Pentium® II /!!!, Cyrix Joshua processor installed	

---

◆ IR : INFRARED Connector (IR) -- Function Option	
Pin No.	Function
1	IR Transmitter Output
2	GND
3	IR Receiver Input
4	NC
5	VCC(+5V)

◆ PWR : Power On LED	
Pin No.	Function
1	LED anode (+)
2	LED cathode (-)
3	LED cathode (-)

◆ SPK : Speaker Connector	
Pin No.	Function
1	VCC
2	NC
3	NC
4	Signal

◆ TD : Turbo LED Connector	
Pin No.	Function
1	LED anode (+)
2	LED cathode (-)

◆ RST : Reset Switch	
Open	Normal operation
Close	Reset system

◆ GD : Green LED Connector	
Pin No.	Function
1	LED anode (+)
2	LED cathode (-)

◆ GN : GN-SW	
Open	Normal operation
Close	Enter Green Mode

◆ HD : Hard Disk active LED (HD-LED)	
Pin No.	Function
1	LED anode (+)
2	LED cathode (-)

◆ Soft PWR : Soft Power Switch	
Pin No.	Function
1	CTRL-Signal
2	GND

◆ J6 : CPU FAN (CPU cooling FAN Power Connector)	
Pin No.	Function
1	Control Signal
2	+12V
3	Sense Signal

◆ J20 : System cooling FAN Power Connector	
Pin No.	Function
1	Control Signal
2	+12V
3	Sense Signal

◆ J21 : Power cooling FAN Power Connector	
Pin No.	Function
1	Control Signal
2	+12V
3	Sense Signal

◆ JP10 : Case Open (Optional)	
Pin No.	Function
1	Signal
2	GND

◆ JP9 : Clear CMOS	
Pin No.	Function
1-2	Clear CMOS
2-3	Normal

◆ J19 : Internal Modem Card Ring Power On	
Pin No.	Function
1	Signal
2	GND

◆ JP1 : Keyboard Power On Selection	
Pin No.	Function
1-2	Enabled Keyboard power on.
2-3	Disabled Keyboard power on.

◆ J11 : Wake on LAN	
Pin No.	Function
1	+5V SB
2	GND
3	Signal

◆ J9 SB-LINK : For PCI Audio / Sound Card use only (Optional)	
Pin No.	Function
1	Signal
2	GND
3	NC
4	Signal
5	GND
6	Signal

### 3.4. DRAM INSTALLATION

The main board can be installed with 16 / 32 / 64 / 128 / 256 / 512 MB(256Mb technology) 168 pins DIMM module DRAM. When system bus speed is set to 100MHz, 100MHz SDRAM is required. The DRAM memory system on main board consists of bank 0, 1& bank 2.

Since 168 pins DIMM module is 64 bits width, therefore 1 piece of DIMM module may match a 64 bits system. The total memory size is 16 MB ~ 1.5GB SDRAM (256Mb technology). The DRAM installation position refer to Figure 3.1, and notice the Pin 1 of DIMM module must match with the Pin 1 of DIMM socket. Insert the DRAM DIMM module into the DIMM socket at Vertical angle. If there is a wrong direction of Pin 1, the DRAM DIMM module could not be inserted into socket completely.

### 3.5. CPU SPEED SETUP

The system bus frequency can be switched at 66MHz, 100MHz and 133MHz by adjusting DIP SW2. The CPU frequency ratio can be switched from X3 to X9.5 by adjusting DIP SW1. The user can set up CPU speed for 300~866MHz processors by adjusting SW1 and SW2 properly.

The CPU speed must match with the frequency RATIO. It will cause system hanging up if the frequency RATIO is higher than CPU's.

#### SW1: (O:ON / X:OFF)

FREQ. RATIO	DIP SWITCH (SW1)			
	1	2	3	4
X 3	O	X	O	O
X 3.5	X	X	O	O
X 4	O	O	X	O
X 4.5	X	O	X	O
X 5	O	X	X	O
X 5.5	X	X	X	O
X 6	O	O	O	X
X 6.5	X	O	O	X
X 7	O	X	O	X
X 7.5	X	X	O	X
X 8	O	O	X	X
X 8.5	X	O	X	X
X 9	O	X	X	X
X 9.5	X	X	X	X

#### Set System Bus Speed

#### SW 2 :

CPU	PCI	1	2	3	4	5	6
AUTO	33.3	X	X	X	X	O	O
66	33.3	O	O	X	X	X	X
75	37.5	O	O	O	X	X	X
83	41.6	O	O	X	O	X	X
100	33.3	O	X	X	X	X	X
112	37.5	O	X	O	X	X	X
124	31	X	X	X	O	X	X

133	33.3	X	X	X	X	X	X
140	37.5	X	X	O	O	X	X
150	35	X	X	O	X	X	X

⚡\* **The CPU is a sensitive electric component and it can be easily damaged by static electricity, so users must keep it away from metal surface when the CPU is installed onto main board.**

### 3.6. CMOS RTC & ISA CFG CMOS SRAM

The mainboard contains RTC & CMOS SRAM on board. They have a power supply from external battery to keep the DATA inviolate & effective. The RTC is a REAL-TIME CLOCK device, which provides the DATE & TIME to system. The CMOS SRAM is used for keeping the information of system configuration, so the system can automatically boot OS every time. Since the lifetime of internal battery is 5 years, the user can change a new Battery to replace old one when it has consumed.

### 3.7. SPEAKER CONNECTOR INSTALLATION

There is a speaker in AT system for sound purpose. The 4 - Pins connector **SPK** is used to connect speaker. Anode connects +, Cathode connects -.

### 3.8. HARDWARE RESET SWITCH CONNECTOR INSTALLATION

The RESET switch on panel provides users with HARDWARE RESET function. The system will do a cold start after the RESET button is pressed and released by user. The RESET switch is a 2 PIN connector and should be installed to **RST** on main board.

### 3.9. POWER LED CONNECTOR INSTALLATION

System has power LED lamp on the panel of case. The power LED will light on/off or flash to indicate which step on the system. The connector should be connected to PWR of main board in correct direction.

### 3.10. IDE & ATAPI DEVICE INSTALLATION

There are two-Enhanced PCI IDE ports (**IDE1**, **IDE2**) on board, which following ATAPI standard SPEC. Any one IDE port can connected to two ATAPI devices (IDE Hard Disk, CD-ROM & Tape Driver), so total four ATAPI devices can exist in a system. The **HD** is the active LED port for ATAPI devices.

### **3.11. PERIPHERAL DEVICE INSTALLATION**

After the I/O device installation and jumpers setup, the main board can be mounted into the case and fixed by screw. To complete the main board installation, the peripheral device could be installed now. The basic system needs a display interface card. If the PCI - Bus device is to be installed in the system, any one of four PCI - Bus slots can be used.

### **3.12. KEYBOARD & PS/2 MOUSE INSTALLATION**

The main board supports PS/2 Mouse. The BIOS will auto detect whether the PS/2 Mouse is installed or not & assign IRQ12 for PS/2 Mouse port if it is installed. After installing the peripheral device, the user should check everything again, and prepare to power-on the system.



## 4. BIOS CONFIGURATION

Award's BIOS ROM has a built-in Setup program that allows users to modify the basic system configuration. This type of information is stored in battery-backed CMOS RAM so that it retains the Setup information when the power is turned off.

### 4.1. ENTERING SETUP

Power ON the computer and press <Del> immediately will allow you to enter Setup. If the message disappears before you respond and you still wish to enter Setup, restart the system to try again by turning it OFF then ON or pressing the "RESET" bottom on the system case. You may also restart by simultaneously press <Ctrl>, <Alt>, and <Del> keys.

### 4.2. CONTROL KEYS

Up arrow	Move to previous item
Down arrow	Move to next item
Left arrow	Move to the item in the left hand
Right arrow	Move to the item in the right hand
Esc key	Main Menu - Quit and not save changes into CMOS Status Page Setup Menu and Option Page Setup Menu - Exit current page and return to Main Menu
PgUp key	Increase the numeric value or make changes
PgDn key	Decrease the numeric value or make changes
F1 key	General help, only for Status Page Setup Menu and Option Page Setup Menu
F2 key	Change color from total 16 colors
F3 key	Reserved
F4 key	Reserved
F5 key	Restore the previous CMOS value from CMOS, only for Option Page Setup Menu
F6 key	Load the default CMOS value from BIOS default table, only for Option Page Setup Menu
F7 key	Load the default
F8 key	Reserved
F9 key	Reserved
F10 key	Save all the CMOS changes, only for Main Menu

## 4.3. GETTING HELP

### 4.3.1. Main Menu

The on-line description of the highlighted setup function is displayed at the bottom of the screen.

### 4.3.2. Status Page Setup Menu / Option Page Setup Menu

Press F1 to pop up a small help window that describes the appropriate keys to use and the possible selections for the highlighted item. To exit the Help Window press <Esc>.

## 4.4. THE MAIN MENU

Once you enter Award BIOS CMOS Setup Utility, the Main Menu (Figure 4.1) will appear on the screen. The Main Menu allows you to select setup functions and exit choices. Use arrow keys to select among the items and press <Enter> to accept or enter the sub-menu.

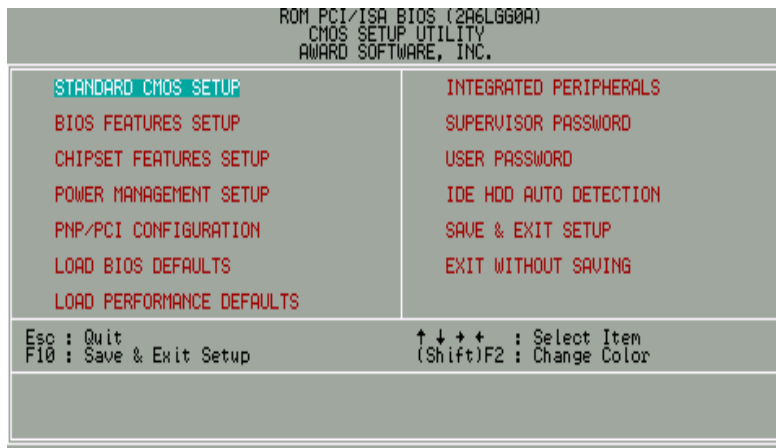

Figure 4.1: Main Menu

- **Standard CMOS setup**

This setup page includes all the items in standard compatible BIOS.

- **BIOS features setup**

This setup page includes all the items of Award special enhanced features.

- **Chipset features setup**

This setup page includes all the items of chipset special features.

- **Power management setup**

This setup page includes all the items of Green function features.

- **PNP/PCI configuration**

This setup page includes all the configurations of PCI & PnP ISA resources.

- **Load BIOS defaults**

BIOS Defaults indicates the most appropriate value of the system parameters that the system would be in safe configuration.

- **Load Performance defaults**

Performance Defaults indicates the value of the system parameters that the system would be in the best performance configuration.

- **Integrated peripherals**

This setup page includes all onboard peripherals.

- **Supervisor password**

Change, set, or disable password. It allows you to limit access to the system and Setup, or just to Setup.

- **User password**

Change, set, or disable password. It allows you to limit access to the system.

- **IDE HDD auto detection**

Automatically configure hard disk parameters.

- **Save & exit setup**

Save CMOS value settings to CMOS and exit setup.

- **Exit without saving**

Abandon all CMOS value changes and exit setup.

#### 4.5. STANDARD CMOS SETUP MENU

The items in Standard CMOS Setup Menu (Figure 4.2) are divided into 9 categories. Each category includes no, one or more than one setup items. Use the arrows to highlight the item and then use the <PgUp> or <PgDn> keys to select the value you want in each item.

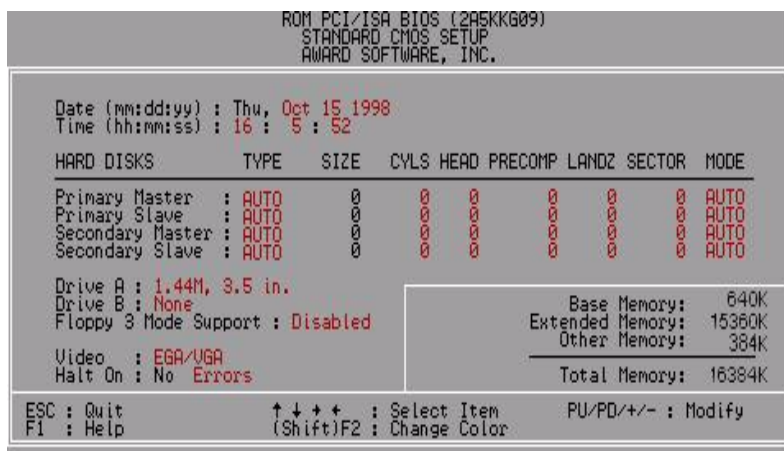

Figure 4.2: Standard CMOS Setup Menu

- **Date**

The date format is <week>, <month> <day> <year>.

week	The week, from Sun to Sat, determined by the BIOS and is display-only
month	The month, Jan. through Dec.
day	The day, from 1 to 31 (or the maximum allowed in the month)
year	The year, from 1994 through 2079

- Time

The times format in <hour> <minute> <second>. The time is calculated base on the 24-hour military-time clock. For example, 1 p.m. is 13:00:00.

- Primary HDDs / Secondary HDDs

The category identifies the types of hard disk from drive C to F that has been installed in the computer. There are two types: auto type, and user definable type. User type is user-definable; Auto type which will automatically detect HDD type.

Note that the specifications of your drive must match with the drive table. The hard disk will not work properly if you enter improper information for this category.

If you select User Type, related information will be asked to enter to the following items. Enter the information directly from the keyboard and press <Enter>. Such information should be provided in the documentation form your hard disk vendor or the system manufacturer.

CYLS.	Number of cylinders
HEADS	number of heads
PRECOMP	write precomp
LANDZONE	Landing zone
SECTORS	number of sectors

If a hard disk has not been installed select NONE and press <Enter>.

- Drive A type / Drive B type

The category identifies the types of floppy disk drive A or drive B that has been installed in the computer.

None	No floppy drive installed
360K, 5.25 in.	5.25 inch PC-type standard drive; 360K byte capacity.
1.2M, 5.25 in.	5.25 inch AT-type high-density drive; 1.2M byte capacity (3.5 inch when 3 Mode is Enabled).
720K, 3.5 in.	3.5 inch double-sided drive; 720K byte capacity
1.44M, 3.5 in.	3.5 inch double-sided drive; 1.44M byte capacity.
2.88M, 3.5 in.	3.5 inch double-sided drive; 2.88M byte capacity.

- Floppy 3 Mode Support (for Japan Area)

Disabled	Normal Floppy Drive.
Drive A	Drive A is 3 mode Floppy Drive.
Drive B	Drive B is 3 mode Floppy Drive.
Both	Drive A & B are 3 mode Floppy Drives.

- Video

The category detects the type of adapter used for the primary system monitor that must match your video display card and monitor. Although secondary monitors are supported, you do not have to select the type in setup.

EGA/VGA	Enhanced Graphics Adapter/Video Graphics Array. For EGA, VGA, SVGA, or PGA monitor adapters
CGA 40	Color Graphics Adapter, power up in 40 column mode
CGA 80	Color Graphics Adapter, power up in 80 column mode
MONO	Monochrome adapter, includes high resolution monochrome adapters

- Halt on

The category determines whether the computer will stop if an error is detected during power up.

NO Errors	The system boot will not stop for any error that may be detected
All Errors	Whenever the BIOS detects a non-fatal error the system will be stopped and you will be prompted
All, But Keyboard	The system boot will not stop for a keyboard error; it will stop for all other errors
All, But Diskette	The system boot will not stop for a disk error; it will stop for all other errors
All, But Disk/Key	The system boot will not stop for a keyboard or disk error; it will stop for all other errors

- **Memory**

The category is display-only which is determined by POST (Power On Self Test) of the BIOS.

**Base Memory**

The POST of the BIOS will determine the amount of base (or conventional) memory installed in the system.

The value of the base memory is typically 512 K for systems with 512 K memory installed on the motherboard, or 640 K for systems with 640 K or more memory installed on the motherboard.

**Extended Memory**

The BIOS determines how much extended memory is present during the POST.

This is the amount of memory located above 1 MB in the CPU's memory address map.

**Expanded Memory**

Expanded Memory in memory defined by the Lotus/Intel/Microsoft (LIM) standard as EMS.

Many standard DOS applications can not utilize memory above 640 K; the Expanded Memory Specification (EMS) swaps memory, which not utilized by DOS with a section, or frame, so these applications, can access all of the system memory.

Memory can be swapped by EMS is usually 64 K within 1 MB or memory above 1 MB, depends on the chipset design.

Expanded memory device driver is required to use memory as Expanded Memory.

**Other Memory**

This refers to the memory located in the 640 K to 1024 K address space. This is memory that can be used for different applications.

DOS uses this area to load device drivers to keep as much base memory free for application programs. Most use for this area is Shadow RAM.

## 4.6. BIOS FEATURES SETUP

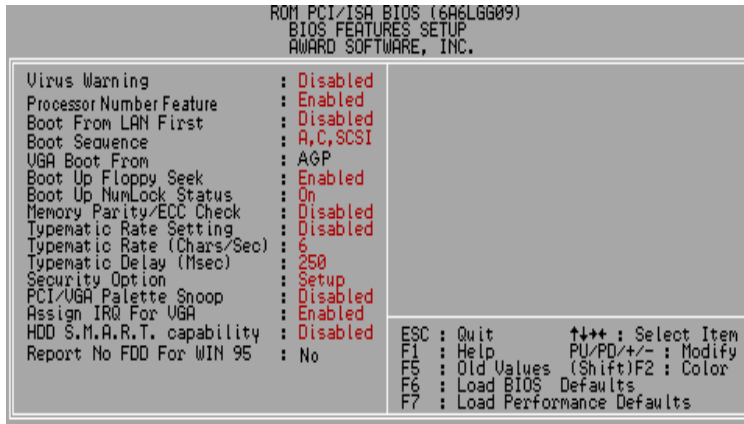

Figure 4.3: BIOS Features Setup

- Virus Warning

If it is set to enable, the category will flash on the screen when there is any attempt to write to the boot sector or partition table of the hard disk drive. The system will halt and the warning message will appear in the mean time. You can run anti-virus program to locate the problem.

The default value is Disabled.

Enabled	Activate automatically when the system boots up causing a warning message to appear when anything attempts to access the boot sector or hard disk partition table.
Disabled	No warning message to appear when anything attempts to access the boot sector or hard disk partition table.

- Processor Number Feature

This item will set Enabled when you install the Pentium® !!! processor

The default value is Enabled.

Enabled	Pentium® !!! Processor Number Feature.
Disabled	Disable this function.



- **Boot From LAN First**

The default value is Disabled.

Enabled	Enabled Boot From LAN First.
Disabled	Disabled Boot From LAN First.
Auto	Boot From LAN First set to Auto.

☞ You can set “Auto” or “Enabled” to boot from LAN first.

- **Boot Sequence**

This category determines which drive computer searches first for the disk operating system (i.e., DOS). Default value is A, C, SCSI.

X1, X2, X3	System will first search for X1 disk drive then X2 disk drive and then X3 disk drive.
------------	---

- **VGA Boot From**

The default value is AGP.

AGP	VGA Boot From AGP.
PCI Slot	VGA Boot From PCI Slot.

- **Boot Up Floppy Seek**

During POST, BIOS will determine the floppy disk drive installed is 40 or 80 tracks. 360 K type is 40 tracks 720 K, 1.2 M and 1.44 M are all 80 tracks. The default value is Enabled.

Enabled	BIOS searches for floppy disk drive to determine it is 40 or 80 tracks. Note that BIOS can not tell from 720 K, 1.2 M or 1.44 M drive type as they are all 80 tracks
Disabled	BIOS will not search for the type of floppy disk drive by track number. Note that there will not be any warning message if the drive installed is 360 K

- Boot Up NumLock Status

The default value is On.

On	Keypad is number keys.
Off	Keypad is arrow keys.

- Memory Parity/ECC Check

The default value is Disabled.

Enabled	Enabled Memory Parity/ECC Check.
Disabled	Disabled Memory Parity/ECC Check.

- Typematic Rate Setting

The default value is Disabled.

Enabled	Enable Keyboard Typematic rate setting.
Disabled	Disable Keyboard Typematic rate setting.

- Typematic Rate (Chars / Sec)

The default value is 6.

6-30	Set the maximum Typematic rate from 6 chars. Per second to 30 chars. Per second.
------	--

- Typematic Delay (Msec)

The default value is 250.

250-1000	Set the time delay from first key to repeat the same key in to computer.
----------	--

- Security Option

This category allows you to limit access to the system and Setup, or just to Setup. The default value is Setup.

System	The system can not boot and can not access to Setup page will be denied if the correct password is not entered at the prompt.
Setup	The system will boot, but access to Setup will be denied if the correct password is not entered at the prompt.

- **To disable security, select PASSWORD SETTING at Main Menu and then you will be asked to enter password. Do not type anything and just press <Enter>, it will disable security. Once the security is disabled, the system will boot and you can enter Setup page freely.**

- PCI/VGA Palette Snoop

The default value is Disabled.

Enabled	For having Video Card on ISA Bus and VGA Card on PCI Bus.
Disabled	For VGA Card only.

- Assign IRQ For VGA

The default value is Enabled.

Enabled	For having Video Card on ISA Bus and VGA Card on PCI Bus.
Disabled	For VGA Card only.

- HDD S.M.A.R.T. Capability

The default value is Disabled.

Enabled	Enabled HDD S.M.A.R.T. Capability.
Disabled	Disabled HDD S.M.A.R.T. Capability.

- Report No FDD For WIN 95

The default value is No.

No	Disabled this function.
Yes	Report No FDD For WIN 95.

## 4.7. CHIPSET FEATURES SETUP

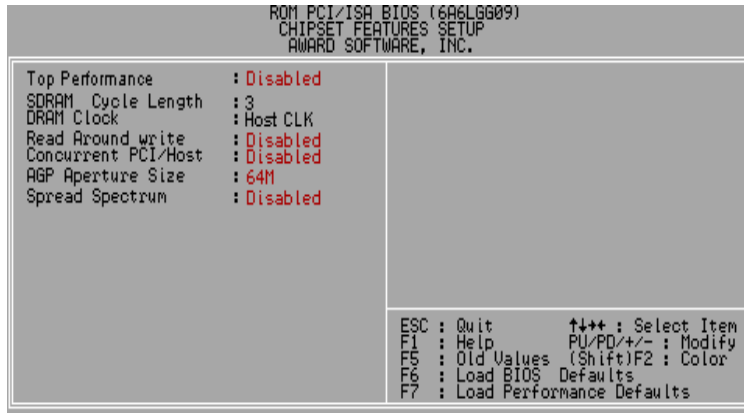

Figure 4.4: Chipset Features Setup

- Top Performance

The default value is Disabled

Disabled	Disabled Top Performance.
Enabled	Enabled Top Performance.

- SDRAM Cycle Length

The default value is 3.

3	For Slower SDRAM DIMM module.
2	For Fastest SDRAM DIMM module.
Auto	CAS latency time will be set automatically if you have SPD on SDRAM.

- DRAM Clock

The default value is Host CLK.

Host CLK	Set DRAM Clock to Host CLK.
HCLK+33M	Set DRAM Clock to HCLK+33M.
Auto	Set DRAM Clock to Auto.

- Read Around write

The default value is Disabled.

Enabled	When set Enabled this feature speeds up data read performance.
Disabled	Normal operation.

- Concurrent PCI/Host

The default value is Disabled.

Enabled	Enabled Concurrent PCI/Host.
Disabled	Disabled Concurrent PCI/Host.

- AGP Aperture Size

The default value is 64M.

4MB	Set AGP Aperture Size to 4MB.
8MB	Set AGP Aperture Size to 8MB.
16MB	Set AGP Aperture Size to 16MB.
32MB	Set AGP Aperture Size to 32MB.
64MB	Set AGP Aperture Size to 64MB.
128MB	Set AGP Aperture Size to 128MB.

- Spread Spectrum

The default value is Disabled.

Disabled	Disabled this function.
Enabled	Enable Spread Spectrum

## 4.8. POWER MANAGEMENT SETUP

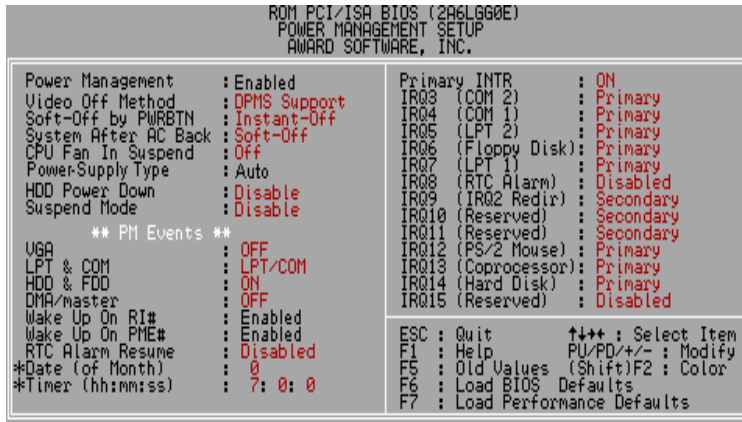

Figure 4.5: Power Management Setup

\* These two items will show up when RTC Alarm Resume is Enabled.

- Power Management

The default value is Enabled.

Enabled	Set Power Management to Enabled.
Min Saving	Set Power Management to Min Saving.
Max Saving	Set Power Management to Max Saving.

- Video off Method

The default value is DPMS Support.

V/H SYNC+Blank	BIOS will turn off V/H-SYNC when gets into Green mode for Green monitor power saving.
Blank Screen	BIOS will only black monitor when gets into Green mode.
DPMS Support	BIOS will use DPMS Standard to control VGA card. (The Green type VGA card will turn off V/H-SYNC automatically.)

- Soft-off by PWR-BTN

The default value is Instant-Off.

Instant-off	Soft switch ON/OFF for POWER ON/OFF.
Delay 4 Sec.	Soft switch ON 4sec. for POWER OFF.

- System After AC Back

The default value is Soft-Off.

Memory	This function depends on computer status
Soft-Off	Set System Soft-Off Status.
Full-On	Set System Full-On Status.

- CPU FAN In Suspend

The default value is Off.

Off	Disabled this function.
On	Stop CPU FAN when entering Suspend mode.

- Power-Supply Type

The default value is AUTO.

AUTO	Auto-detect which type of power supply is used.
ATX	Power-Supply Type is ATX.
AT	Power-Supply Type is AT.

- HDD Power Down

The default value is Disabled.

Disabled	Disable HDD Power Down mode function.
1-15 mins.	Enable HDD Power Down mode between 1 to 15 mins.

- Suspend Mode

The default value is Disabled.

Disabled	Disable Suspend Mode.
10Sec - 1 Hour	Setup the timer to enter Suspend Mode.

- VGA

The default value is OFF.

OFF	Disable monitor VGA activity.
ON	Enable monitor VGA activity.

- LPT & COM

The default value is LPT/COM.

LPT/COM	Enabled LPT/COM Ports Activity.
NONE	Normal Operation.
LPT	Enabled LPT Ports Activity.
COM	Enabled COM Ports Activity.

- HDD & FDD

The default value is ON.

ON	Enabled HDD & FDD Ports Activity.
OFF	Disabled HDD & FDD Ports Activity.

- DMA/master

The default value is OFF.

ON	Don't detect DMA/master PM event.
OFF	Normal Operation.

- Wake Up On RI#

The default value is Enabled.

Disabled	Disabled this function.
Enabled	Enabled Wake Up On RI#.

- Wake Up On PME#

The default value is Enabled.

Disabled	Disabled this function.
Enabled	Enabled Wake Up On PME#.



- RTC Alarm Resume

You can set "RTC Alarm Resume" item to Enabled and key in date/time to power on system. The default value is Disabled.

Disabled	Disable this function.
Enabled	Enable alarm function to POWER ON system.

If the "RTC Alarm Resume" is Enabled.

Date ( of Month) Alarm :	0~31
Time ( hh: mm: ss) Alarm :	(0~23) : (0~59) : (0~59)

- Primary INTR

The default value is ON.

OFF	Disabled this function.
ON	Enabled Primary INTR Function.

- IRQ [3-7,9-15]

The default value is Primary/Secondary/Disabled.

Disabled	Disabled this function.
Primary	The resource is used by Primary device .
Secondary	The resource is used by Secondary device .

#### 4.9. PNP/PCI CONFIGURATION

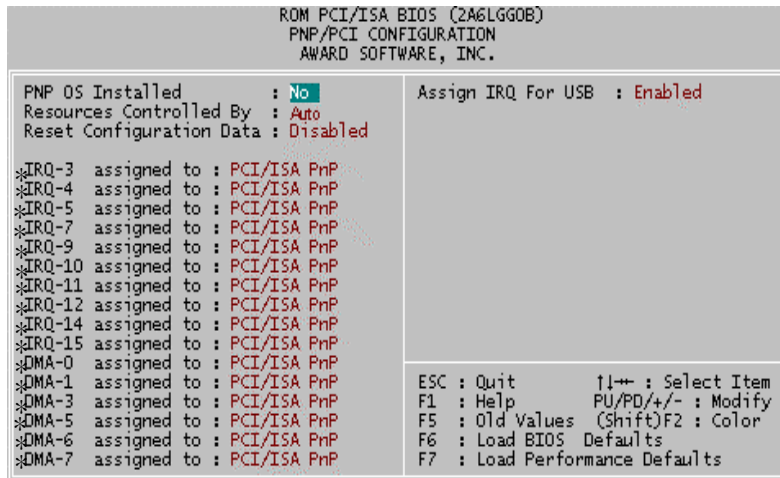

Figure 4.6: PCI Slot Configuration

\* IRQ[3.4.5.7.9.10.11.12.14.15] & DMA[0.1.3.5.6.7] these items will show up when “Resources Controlled By” is set to Manual.

- PNP OS Installed

The default value is No.

Yes	Enable PNP OS Installed function.
No	Disable PNP OS Installed function.

- Resources Controlled By

The default value is Auto.

Manual	User can set the PnP resource (I/O Address, IRQ & DMA channels) used by legacy ISA DEVICE.
Auto	BIOS automatically use these PnP resources.

- Reset Configuration Data

The default value is Disabled.

Disabled	Disabled this function.
ESCD	Clear PnP information in ESCD.
DMI	Update Desktop Management Information data.
Both	Clear PnP information in ESCD & update DMI data.

- IRQ (3,4,5,7,9,10,11,12,14,15), DMA(0,1,3,5,6,7) assigned to

The default value is "Legacy ISA" or "PCI/ISA PnP".

Legacy ISA	The resource is used by Legacy ISA device.
PCI/ISA PnP	The resource is used by PCI/ISA PnP device (PCI or ISA).

- Assign IRQ For USB

The default value is Enabled.

Enabled	Assign a specific IRQ for USB.
Disabled	No IRQ is assigned for USB.



#### 4.11. LOAD PERFORMANCE DEFAULTS

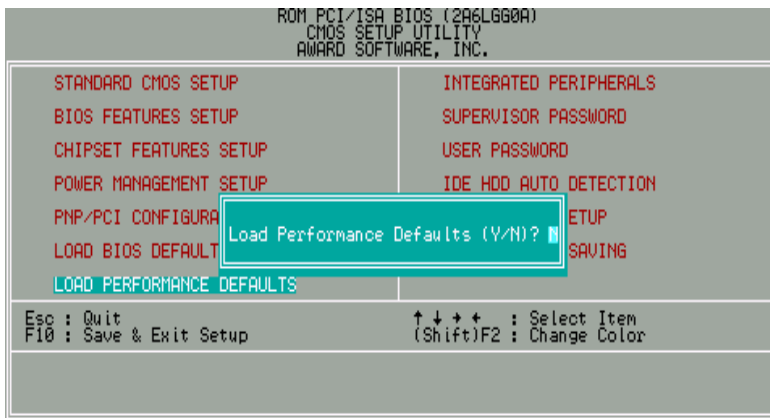

Figure 4.8: Load Performance Defaults

- Load PERFORMANCE Defaults

To load PERFORMANCE defaults value to CMOS, enter "Y". If not, enter "N".

## 4.12. INTEGRATED PERIPHERALS

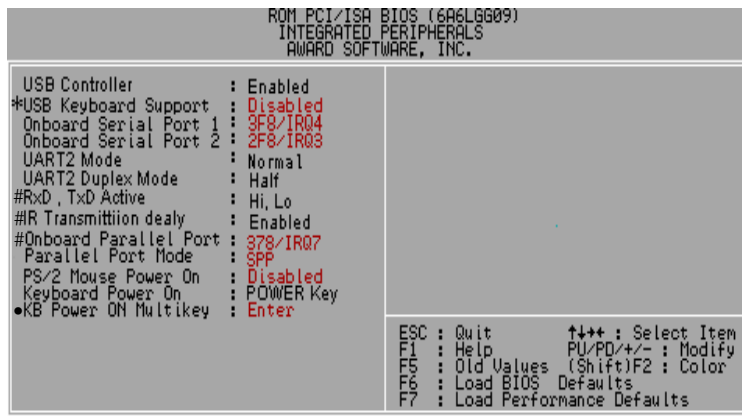

Figure 4.9: Integrated Peripherals

\* When USB Controller set “Disabled”, USB Keyboard Support will be hidden.

# These three items will show up when “UART2 Mode Select” is set to IrDA or ASKIR.

• This item will show up when “Keyboard Power On: Multikey” is selected.

- USB Controller

The default value is Enabled.

Enabled	Enabled Onchip USB port.
Disabled	Disabled Onchip USB port.

- USB Keyboard Support

The default value is Disabled.

Enabled	Enabled USB Keyboard Support.
Disabled	Disabled USB Keyboard Support.

- Onboard Serial Port 1

The default value is 3F8/IRQ4.

Auto	BIOS will automatically setup the port 1 address.
3F8/IRQ4	Enable onboard Serial port 1 and address is 3F8.
2F8/IRQ3	Enable onboard Serial port 1 and address is 2F8.
3E8/IRQ4	Enable onboard Serial port 1 and address is 3E8.
2E8/IRQ3	Enable onboard Serial port 1 and address is 2E8.
Disabled	Disable onboard Serial port 1.

- Onboard Serial Port 2

The default value is 2F8/IRQ3.

Auto	BIOS will automatically setup the port 2 address.
3F8/IRQ4	Enable onboard Serial port 2 and address is 3F8.
2F8/IRQ3	Enable onboard Serial port 2 and address is 2F8.
3E8/IRQ4	Enable onboard Serial port 2 and address is 3E8.
2E8/IRQ3	Enable onboard Serial port 2 and address is 2E8.
Disabled	Disable onboard Serial port 2.

- UART2 Mode Select

(This item allows you to determine which UART2 Mode of onboard I/O chip), the default value is Normal.

ASKIR	Set onboard I/O chip UART2 to ASKIR Mode.
IrDA	Set onboard I/O chip UART2 to IrDA Mode.
Normal	Set onboard I/O chip UART2 to Normal Mode.

- UART2 Duplex Mode

The default value is Half.

Half	Set UART2 Duplex Mode to Half.
Full	Set UART2 Duplex Mode to Full.

- RxD , TxD Active

The default value is Hi, Lo.

Hi, Hi	RxD set Hi, TxD set Hi.
Hi, Lo	RxD set Hi, TxD set Lo.
Lo, Hi	RxD set Lo, TxD set Hi.
Lo, Lo	RxD set Lo, TxD set Lo.

- IR Transmittiion delay

The default value is Enabled.

Enabled	Set IR Transmittiion delay Enabled.
Disabled	Set IR Transmittiion delay Disabled.

- Onboard Parallel port

The default value is 378/IRQ7.

378/IRQ7	Enable onboard LPT port and address is 378/IRQ7.
278/IRQ5	Enable onboard LPT port and address is 278/IRQ5.
Disabled	Disable onboard LPT port.
3BC/IRQ7	Enable onboard LPT port and address is 3BC/IRQ7.

- Parallel Port Mode

The default value is SPP.

SPP	Using Parallel port as Standard Parallel Port.
EPP	Using Parallel port as Enhanced Parallel Port.
ECP	Using Parallel port as Extended Capabilities Port.
ECP/EPP	Using Parallel port as ECP/EPP mode.

- PS/2 Mouse Power on

The default value is Disabled.

Disabled	Disable PS/2 Mouse Power on .
Left Double	Double Click on PS/2 mouse left button to Power on system.
Right Double	Double Click on PS/2 mouse right button to Power on system.



- Keyboard Power on

The default value is POWER Key.

Disabled	Disable Keyboard Power on .
Multikey	Enter multikey combination to Power on system.
POWER Key	If your keyboard have "POWER Key" button, you can press the key to power on your system.

- KB Power ON Multikey

Enter	Enter from 1 to 5 characters to set the Keyboard Power On Password.
-------	---

You can power on your system by entering password from the Keyboard after setting the "Keyboard power on" jumper and password in CMOS Setup.

#### 4.13. SUPERVISOR / USER PASSWORD

When you select this function, the following message will appear at the center of the screen to assist you in creating a password.

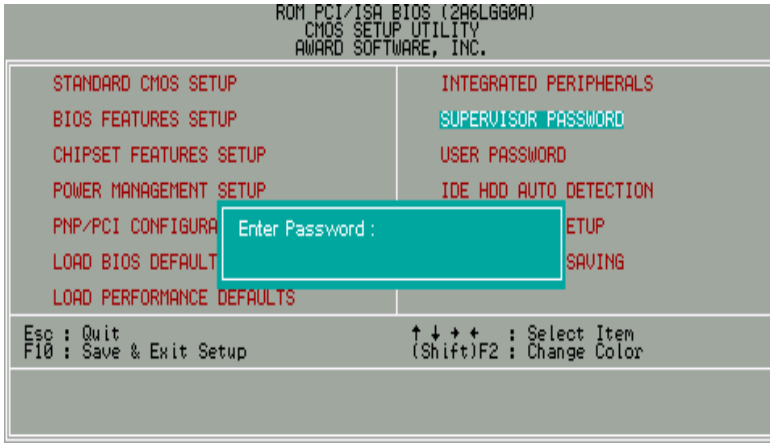

Figure 4.10: Password Setting

Type the password, up to eight characters, and press <Enter>. The password typed now will clear the previously entered password from CMOS memory. You will be asked to confirm the password. Type the password again and press <Enter>.

To disable password, just press <Enter> when you are prompted to enter password. A message "PASSWORD DISABLED" will appear to confirm the password being disabled. Once the password is disabled, the system will boot and you can enter Setup freely.

If you select System at Security Option in BIOS Features Setup Menu, you will be prompted for the password every time the system is rebooted or any time you try to enter Setup Menu. If you select Setup at Security Option in BIOS Features Setup Menu, you will be prompted only when you try to enter Setup.

#### 4.14. IDE HDD AUTO DETECTION

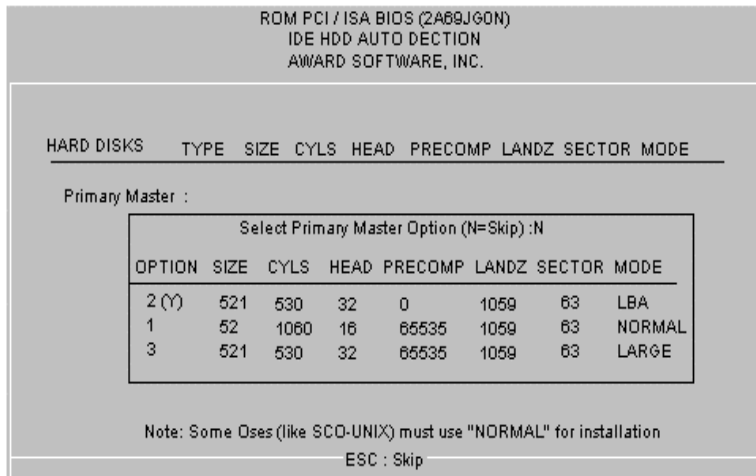

Figure 4.11: IDE HDD Auto Detection

Type "Y" will accept the H.D.D. parameter reported by BIOS.

Type "N" will keep the old H.D.D. parameter setup. If the hard disk cylinder number is over 1024, then the user can select LBA mode or LARGER mode for DOS partition larger than 528 MB.

#### 4.15. SAVE & EXIT SETUP

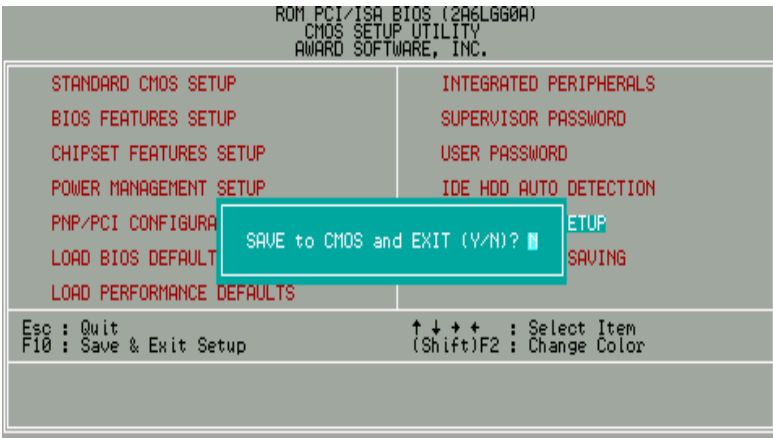

Figure 4.12: Save & Exit Setup

Type "Y" will quit the Setup Utility and save the user setup value to RTC CMOS.

Type "N" will return to Setup Utility.

#### 4.16. EXIT WITHOUT SAVING

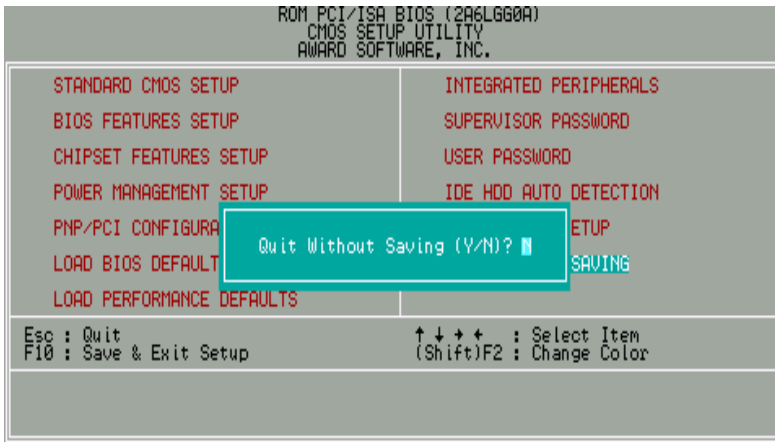

Figure 4.13: Exit Without Saving

Type "Y" will quit the Setup Utility without saving to RTC CMOS.

Type "N" will return to Setup Utility.



## Appendix A: VIA Chipsets Driver Installation

### a. VIA 4 in 1 Service Pack Utility:

Insert the support CD that came with your motherboard into your CD-ROM driver or double-click the CD driver icon in My Computer to bring up the screen.

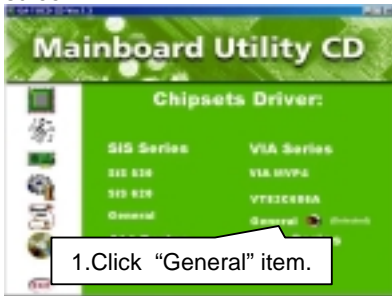

(1)

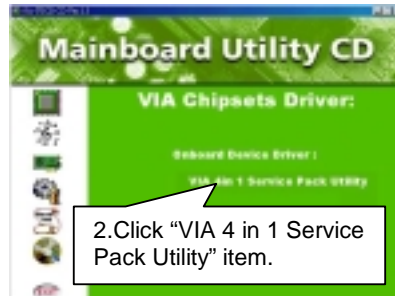

(2)

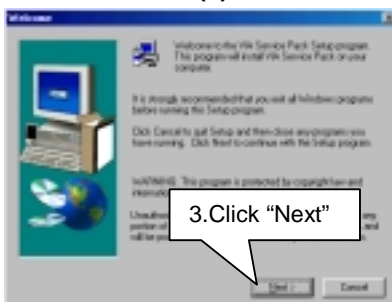

(3)

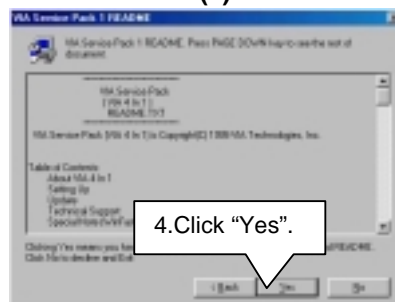

(4)

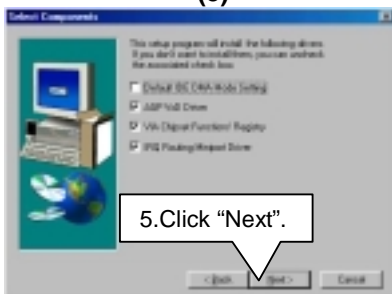

(5)

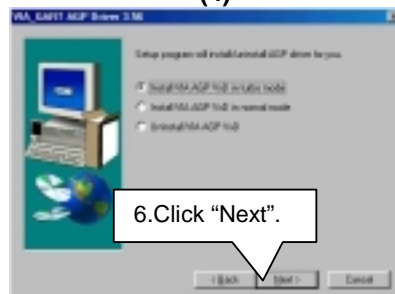

(6)

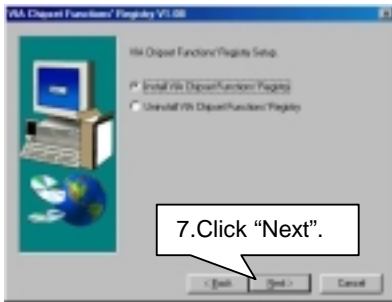

(7)

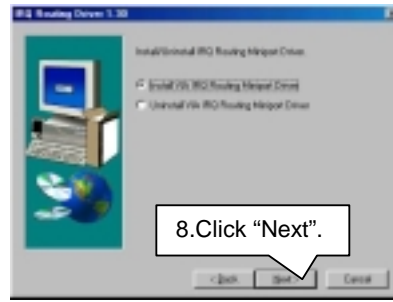

(8)

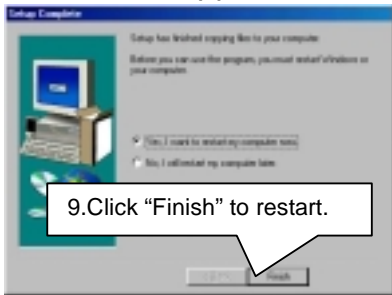

(9)



## **Appendix B: Bugs & Limitations**

1. For some SDRAM Modules, when you are running Winstone 99 (Business Winstone 99) under the Windows NT4.0 operating system, the following error message may appear:

“ mtrun-exe-Bad image: The application or DLL C:\WINNT\System \MSVCRi40.DLL is not a valid Windows NT image. Please check this against your installation diskette.”



## Appendix C: BIOS Flash Procedure

BIOS update procedure:

- ✓ Please check your BIOS vendor (AMI or AWARD) on the motherboard.
- ✓ It is recommended you copy the AWDFlash.exe or AMIFlash.exe in driver CD (D:\>Utility\BIOSFlash) and the BIOS binary files into the directory you made in your hard disk. 【 i.e:C:\>Utility\ (C:\>Utility : denotes the driver and the directory where you put the flash utilities and BIOS file in.)】
- ✓ Restart your computer into MS-DOS mode or command prompt only for Win95/98, go into the directory where the new BIOS file are located use the utility AWDFlash.exe or AMIFlash.exe to update the BIOS.
- ✓ Type the following command once you have enter the directory where all the files are located  
C:\utility\ AWDFlash or AMIFlash <filename of the BIOS binary file intended for flashing>
- ✓ Once the process is finished, reboot the system

◆ Note: Please download the newest BIOS from our website ([www.gigabyte.com.tw](http://www.gigabyte.com.tw)) or contact your local dealer for the file.



<p align="center"><b>DECLARATION OF CONFORMITY</b> Per FCC Part 2, Section 2.107(a)</p> <p align="center"><b>FCC</b></p> <p>Responsible Party Name: G.B.T. INC.</p> <p>Address: 48385 Valley Blvd., Suite#A LA Point, CA 91744</p> <p>Phone/Fax No: (818) 854-9338 / (818) 854-9339</p> <p>I hereby declare that the product</p> <p><b>Product Name:</b> Mother Board</p> <p><b>Model Number:</b> GA-6VA+</p> <p>Conforms to the following specifications:</p> <p>FCC Part 15, Subpart B, Section 15.107(a) and Section 15.109(a), Class B Digital Device</p> <p><b>Supplementary Information:</b></p> <p>This device complies with part 15 of the FCC Rules. Operation is subject to the following two conditions: (1) This device may not cause harmful interference and (2) this device must accept any interference received, including that which may cause undesired operation.</p> <p>Representative Person's Name: <u>ERIC LU</u></p> <p>Signature: <u>Eric Lu</u></p> <p>Date: <u>Mar. 31, 2000</u></p>
--

**FCC Compliance Statement:**

This equipment has been tested and found to comply with limits for a Class B digital device , pursuant to Part 15 of the FCC rules. These limits are designed to provide reasonable protection against harmful interference in residential installations. This equipment generates, uses, and can radiate radio frequency energy, and if not installed and used in accordance with the instructions, may cause harmful interference to radio communications. However, there is no guarantee that interference will not occur in a particular installation. If this equipment does cause

interference to radio or television equipment reception, which can be determined by turning the equipment off and on, the user is encouraged to try to correct the interference by one or more of the following measures:

- Reorient or relocate the receiving antenna
- Move the equipment away from the receiver
- Plug the equipment into an outlet on a circuit different from that to which the receiver is connected
- Consult the dealer or an experienced radio/television technician for additional suggestions

You are cautioned that any change or modifications to the equipment not expressly approve by the party responsible for compliance could void Your authority to operate such equipment.

This device complies with Part 15 of the FCC Rules. Operation is subjected to the following two conditions 1) this device may not cause harmful interference and 2) this device must accept any interference received, including interference that may cause undesired operation.

## Declaration of Conformity

We, Manufacturer/Importer  
(full address)

**G.B.T. Technology Trading GMBH**  
**Ausschlager Weg 41, 1F, 20537 Hamburg, Germany**

declare that the product  
(description of the apparatus, system, installation to which it refers)

**Mother Board**  
GA-6VA+

is in conformity with  
(reference to the specification under which conformity is declared)  
in accordance with 89/336 EEC-EMC Directive

- |   |  |  |  |
|---|--|--|--|
| <input type="checkbox"/> EN 55011   | Limits and methods of measurement of radio disturbance characteristics of industrial, scientific and medical (ISM high frequency equipment)                | <input type="checkbox"/> EN 61000-3-2*<br><input type="checkbox"/> EN60555-2 | Disturbances in supply systems caused by household appliances and similar electrical equipment "Harmonics"   |
| <input type="checkbox"/> EN55013  | Limits and methods of measurement of radio disturbance characteristics of broadcast receivers and associated equipment                                     | <input type="checkbox"/> EN61000-3-3*<br><input type="checkbox"/> EN60555-3  | Disturbances in supply systems caused by household appliances and similar electrical equipment "Voltage fluctuations"                                  |
| <input type="checkbox"/> EN 55014   | Limits and methods of measurement of radio disturbance characteristics of household electrical appliances, portable tools and similar electrical apparatus | <input type="checkbox"/> EN 50081-1<br><input type="checkbox"/> EN 50082-1   | Generic emission standard Part 1: Residual, commercial and light industry<br>Generic immunity standard Part 1: Residual, commercial and light industry |
| <input type="checkbox"/> EN 55015   | Limits and methods of measurement of radio disturbance characteristics of fluorescent lamps and luminaries   | <input type="checkbox"/> EN 55081-2  | Generic emission standard Part 2: Industrial environment   |
| <input type="checkbox"/> EN 55020   | Immunity from radio interference of broadcast receivers and associated equipment   | <input type="checkbox"/> EN 55082-2  | Generic immunity standard Part 2: Industrial environment   |
| <input type="checkbox"/> EN 55022   | Limits and methods of measurement of radio disturbance characteristics of information technology equipment   | <input type="checkbox"/> ENV 55104   | Immunity requirements for household appliances tools and similar apparatus   |
| <input type="checkbox"/> DIN VDE 0855<br><input type="checkbox"/> part 10<br><input type="checkbox"/> part 12 | Cabled distribution systems; Equipment for receiving and/or distribution from sound and television signals   | <input type="checkbox"/> EN 50091-2  | EMC requirements for uninterruptible power systems (UPS)   |

CE marking



**The manufacturer also declares the conformity of above mentioned product with the actual required safety standards in accordance with LVD 73/23 EEC**

- |                                   |   |                                     |   |
|-----------------------------------|---|-------------------------------------|---|
| <input type="checkbox"/> EN 60065 | Safety requirements for mains operated electronic and related apparatus for household and similar general use | <input type="checkbox"/> EN 60950   | Safety for information technology equipment including electrical business equipment |
| <input type="checkbox"/> EN 60335 | Safety of household and similar electrical appliances   | <input type="checkbox"/> EN 50091-1 | General and Safety requirements for uninterruptible power systems (UPS)             |

**Manufacturer/Importer**

(Stamp)

Date: Mar. 31, 2000

Signature : Rex Lin  
Name : Rex Lin