

**ASUS<sup>®</sup> P/I-P55T2P4S**

Pentium Motherboard with  
Ultra Fast/Wide SCSI

**USER'S MANUAL**

# USER'S NOTICE

---

No part of this product, including the product and software may be reproduced, transmitted, transcribed, stored in a retrieval system, or translated into any language in any form by any means without the express written permission of ASUSTeK COMPUTER INC. (hereinafter referred to as ASUS) except documentation kept by the purchaser for backup purposes.

ASUS provides this manual "as is" without warranty of any kind, either express or implied, including but not limited to the implied warranties or conditions of merchantability or fitness for a particular purpose. In no event shall ASUS be liable for any loss or profits, loss of business, loss of use or data, interruption of business, or for indirect, special, incidental, or consequential damages of any kind, even if ASUS has been advised of the possibility of such damages arising from any defect or error in this manual or product. ASUS may revise this manual from time to time without notice.

Products mentioned in this manual are mentioned for identification purposes only. Product names appearing in this manual may or may not be registered trademarks or copyrights of their respective companies.

The product name and revision number are both printed on the board itself. Manual revisions are released for each board design represented by the digit before and after the period of the manual revision number. Manual updates are represented by the third digit in the manual revision number. For updated BIOS, drivers, or product release information you may visit ASUS' home page at: <http://www.asus.com.tw/>

© Copyright 1996 ASUSTeK COMPUTER INC. All rights reserved.

© Copyright 1995 Adaptec, Inc. All rights reserved. Adaptec, the Adaptec logo, and EZ-SCSI are trademarks of Adaptec, Inc. which may be registered in some jurisdictions.

Product Name:	<b>ASUS P/I-P55T2P4S</b>
Manual Revision:	<b>1.20</b>
Release Date:	<b>November 1996</b>

# ASUS CONTACT INFORMATION

---

## ASUSTeK COMPUTER INC.

### *Marketing Info:*

Address: 150 Li-Te Road, Peitou, Taipei, Taiwan, ROC

Telephone: 886-2-894-3447

Fax: 886-2-894-3449

Email: [info@asus.com.tw](mailto:info@asus.com.tw)

### *Technical Support:*

Fax: 886-2-895-9254

BBS: 886-2-896-4667

Email: [tsd@asus.com.tw](mailto:tsd@asus.com.tw)

WWW: <http://www.asus.com.tw/>

Gopher: <gopher.asus.com.tw>

FTP: <ftp.asus.com.tw/pub/ASUS>

## ASUS COMPUTER INTERNATIONAL

### *Marketing Info:*

Address: 721 Charcot Avenue, San Jose, CA 95131, USA

Telephone: 1-408-474-0567

Fax: 1-408-474-0568

Email: [info-usa@asus.com.tw](mailto:info-usa@asus.com.tw)

### *Technical Support:*

BBS: 1-408-474-0555

Email: [tsd-usa@asus.com.tw](mailto:tsd-usa@asus.com.tw)

## ASUS COMPUTER GmbH

### *Marketing Info:*

Address: Harkort Str. 25, 40880 Ratingen, BRD, Germany

Telephone: 49-2102-445011

Fax: 49-2102-442066

Email: [info-ger@asus.com.tw](mailto:info-ger@asus.com.tw)

### *Technical Support:*

BBS: 49-2102-448690

Email: [tsd-ger@asus.com.tw](mailto:tsd-ger@asus.com.tw)

# CONTENTS

---

<b>I. INTRODUCTION .....</b>	<b>1</b>
How this manual is organized .....	1
Item Checklist .....	1
<b>II. FEATURES .....</b>	<b>2</b>
Features of the ASUS Motherboard .....	2
Parts of the ASUS Motherboard .....	3
<b>III. INSTALLATION .....</b>	<b>4</b>
Map of the ASUS Motherboard .....	4
Installation Steps .....	6
1. Jumpers .....	6
Jumper Settings .....	7
TAG SRAM Upgrade .....	7
Cyrix CPU Identification .....	11
2. System Memory (DRAM & SRAM) .....	12
DRAM Memory Installation Procedures: .....	13
3. Central Processing Unit (CPU) .....	15
4. Expansion Cards .....	16
Expansion Card Installation Procedure: .....	16
Assigning IRQs for Expansion Cards .....	16
Assigning DMA Channels for ISA Cards .....	17
5. External Connectors .....	18
Power Connection Procedures .....	25
<b>IV. BIOS SOFTWARE .....</b>	<b>26</b>
Support Software .....	26
Flash Memory Writer Utility .....	26
Main Menu .....	26
Advanced Features Menu .....	27
Updating your Motherboard's BIOS .....	28
6. BIOS Setup .....	29
Load Defaults .....	30
Standard CMOS Setup .....	30
Details of Standard CMOS Setup: .....	31

# CONTENTS

---

BIOS Features Setup .....	34
Details of BIOS Features Setup: .....	34
Chipset Features Setup .....	37
Power Management Setup .....	40
Details of Power Management Setup: .....	40
PNP and PCI Setup .....	42
Load BIOS Defaults .....	44
Load Setup Defaults .....	44
Supervisor Password and User Password .....	45
IDE HDD Auto Detection .....	46
Save and Exit Setup .....	47
Exit Without Saving .....	47
<b>V. DESKTOP MANAGEMENT .....</b>	<b>49</b>
Desktop Management Interface (DMI) .....	49
Introducing the ASUS DMI Configuration Utility .....	49
System Requirements .....	49
Using the ASUS DMI Configuration Utility .....	50
Notes: .....	50
<b>VI. ADAPTEC EZ-SCSI UTILITY .....</b>	<b>53</b>
Quick Start Instructions .....	53
Windows95 or WindowsNT .....	53
Windows/Windows for Workgroups 3.1x .....	53
DOS .....	53
Troubleshooting Tips .....	54
SCSI Device Troubleshooting .....	54
Windows95/WindowsNT Troubleshooting .....	54
Information for DOS/Windows 3.1x Users .....	57
DOS and Windows3.1x Device Drivers .....	57
DOS and Windows3.1x ASPI Managers .....	57
DOS Formatting Utilities .....	58
Low-level Formatter (scsifmt) .....	58
Formatter and Partitioner (afdisk) .....	59
Removable Media Manager (rmvtool) .....	61
<b>VII. ADAPTEC 7800 DRIVERS (88 Pages)</b>	
(for onboard Adaptec 7880 SCSI Chipset)	

# FCC & DOC COMPLIANCE

---

## ***Federal Communications Commission Statement***

This device complies with FCC Rules Part 15. Operation is subject to the following two conditions:

- This device may not cause harmful interference, and
- This device must accept any interference received, including interference that may cause undesired operation.

This equipment has been tested and found to comply with the limits for a Class B digital device, pursuant to Part 15 of the FCC Rules. These limits are designed to provide reasonable protection against harmful interference in a residential installation. This equipment generates, uses and can radiate radio frequency energy and, if not installed and used in accordance with manufacturer's instructions, may cause harmful interference to radio communications. However, there is no guarantee that interference will not occur in a particular installation. If this equipment does cause harmful interference to radio or television reception, which can be determined by turning the equipment off and on, the user is encouraged to try to correct the interference by one or more of the following measures:

- Re-orient or relocate the receiving antenna.
- Increase the separation between the equipment and receiver.
- Connect the equipment to an outlet on a circuit different from that to which the receiver is connected.
- Consult the dealer or an experienced radio/TV technician for help.

**WARNING:** The use of shielded cables for connection of the monitor to the graphics card is required to assure compliance with FCC regulations. Changes or modifications to this unit not expressly approved by the party responsible for compliance could void the user's authority to operate this equipment.

## ***Canadian Department of Communications Statement***

This digital apparatus does not exceed the Class B limits for radio noise emissions from digital apparatus set out in the Radio Interference Regulations of the Canadian Department of Communications.

# I. INTRODUCTION

---

## How this manual is organized

This manual is divided into the following sections:

- |                             |   |
|-----------------------------|---|
| <b>I. Introduction:</b>     | Manual information and checklist            |
| <b>II. Features:</b>        | Information and specifications              |
| <b>III. Installation:</b>   | Instructions on setting up the motherboard  |
| <b>IV. BIOS Setup:</b>      | BIOS software setup information             |
| <b>V. DMI Utility:</b>      | BIOS supported Desktop Management Interface |
| <b>VI. Adaptec Utility:</b> | Adaptec SCSI Select & EZ-SCSI utilities     |
| <b>VII. Adaptec 7800:</b>   | Adaptec SCSI driver installation and usage  |

## Item Checklist

Please check that your package is complete. If you discover damaged or missing items, please contact your retailer.

- The ASUS P/I-P55T2P4S motherboard
- 2 serial port ribbon cables attached to a mounting bracket
- 1 parallel ribbon cable with mounting bracket
- 1 IDE ribbon cable
- 1 floppy ribbon cable
- 50-Pin Fast-SCSI cable
- Support software (view FILELIST.TXT for contents and descriptions)
  - Flash Memory Writer utility to update the FLASH BIOS
  - Desktop Management Interface (DMI) utility
  - Bus Master IDE Drivers for various operating systems
  - Adaptec SCSI drivers and utilities
  - Technical Support Form
- This user's manual
- Optional PS/2 mouse cable with mounting bracket
- Optional infrared module
- Optional 68-Pin Fast&Wide-SCSI cable

## II. FEATURES

---

### Features of the ASUS Motherboard

The ASUS P/I-P55T2P4S is carefully designed for the demanding corporate PC manager who wants many features in a small package for use as a workstation or server. This motherboard:

- **Easy Installation:** Is equipped with BIOS that supports auto detection of hard drives, PS/2 mouse, and Plug and Play devices to make setup of hard drives, expansion cards, and other devices virtually automatic.
- **Multi-Processor/Multi-Speed Support:** Supports one Intel P54C Pentium (75-200MHz), Intel P55C Pentium (200MHz), Cyrix P166+ (Rev 2.7 or later), or AMD-K5 (PR75-100MHz) (See page 10).
- **Intel Chipset:** Features Intel's 430HX PCIset with I/O subsystems.
- **Adaptec SCSI Chipset:** Features Adaptec's 7880 Ultra-Fast/Wide SCSI Chipset.
- **Error Checking and Correcting (ECC):** Using Intel's 430HX PCIset together with parity DRAM modules can detect multi-bit memory errors and correct 1-bit memory errors.
- **Desktop Management Interface (DMI):** Supports DMI through BIOS which allows hardware to communicate within a standard protocol creating a higher level of compatibility. (Requires DMI-enabled components.) (See section V)
- **L2 Cache:** Provides 512KB onboard Pipelined Burst SRAM.
- **Versatile DRAM Memory Support:** Supports (6) 72-pin SIMMs of 4MB, 8MB, 16MB, 32MB, or 64MB to form a memory size between 8MB to 384MB. Supports both Fast Page Mode (FPM) and Extended Data Output (EDO) SIMMs
- **ISA and PCI Expansion Slots:** Provides three 16-bit ISA slots, three 32-bit PCI slots, and one PCI/MediaBus 2.0 which allows the use of either a standard PCI card or the ASUS MediaBus Card.
- **ASUS MediaBus Rev 2.0:** Features an expansion slot extension shared with PCI Slot 4 for an optional high-performance expansion card which includes two functions in one easy-to-install card.
- **Super Multi-I/O:** Provides two high-speed UART compatible serial ports and one parallel port with EPP and ECP capabilities. UART2 can also be directed from COM2 to the Infrared Module for wireless connections. Two floppy drives of either 5.25" or 3.5" (1.44MB or 2.88MB) are also supported without an external card. **The Japanese "Floppy 3 mode" (3.5" 1.2MB) floppy standard is also supported.**
- **PCI Bus Master IDE Controller:** Comes with an onboard PCI Bus Master IDE controller with two connectors that supports four IDE devices in two channels, provides faster data transfer rates, and supports Enhanced IDE devices such as Tape Backup and CD-ROM drives. This controller supports PIO Modes 3 and 4 and Bus Master IDE DMA Mode 2. **BIOS now supports IDE CD-ROM or SCSI bootup.**



# II. FEATURES

- **50-Pin SCSI & 68-Pin SCSI Connectors:** Supports 50-Pin Ultra-Fast SCSI & 68-Pin Ultra-Wide SCSI through onboard connectors.
- **Optional IrDA and PS/2 Mouse Connector:** This motherboard supports an optional infrared port module for wireless interface and a PS/2 mouse cable set.

## Parts of the ASUS Motherboard

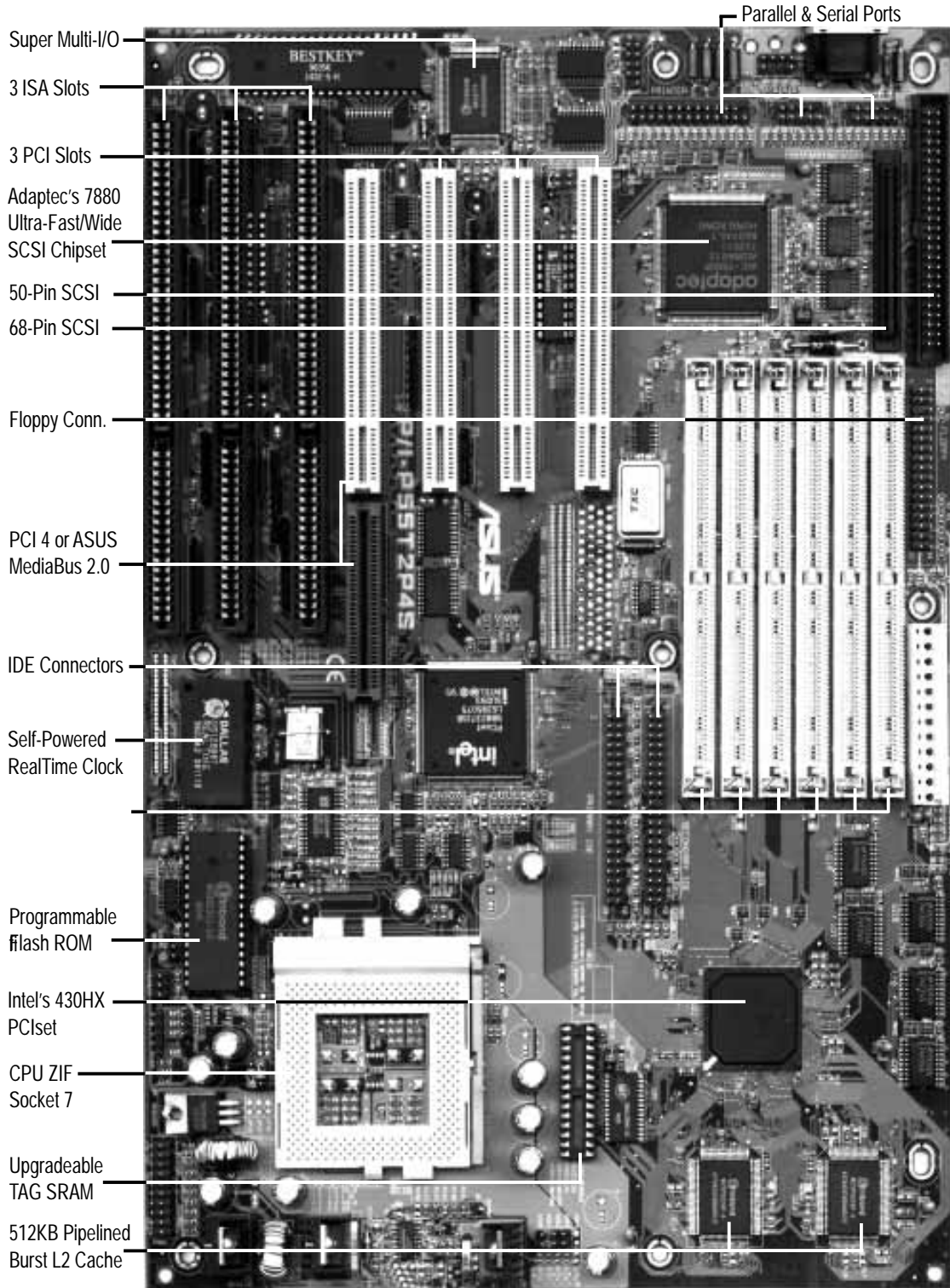

**II. FEATURES**  
(Parts of Board)

# III. INSTALLATION

## Map of the ASUS Motherboard

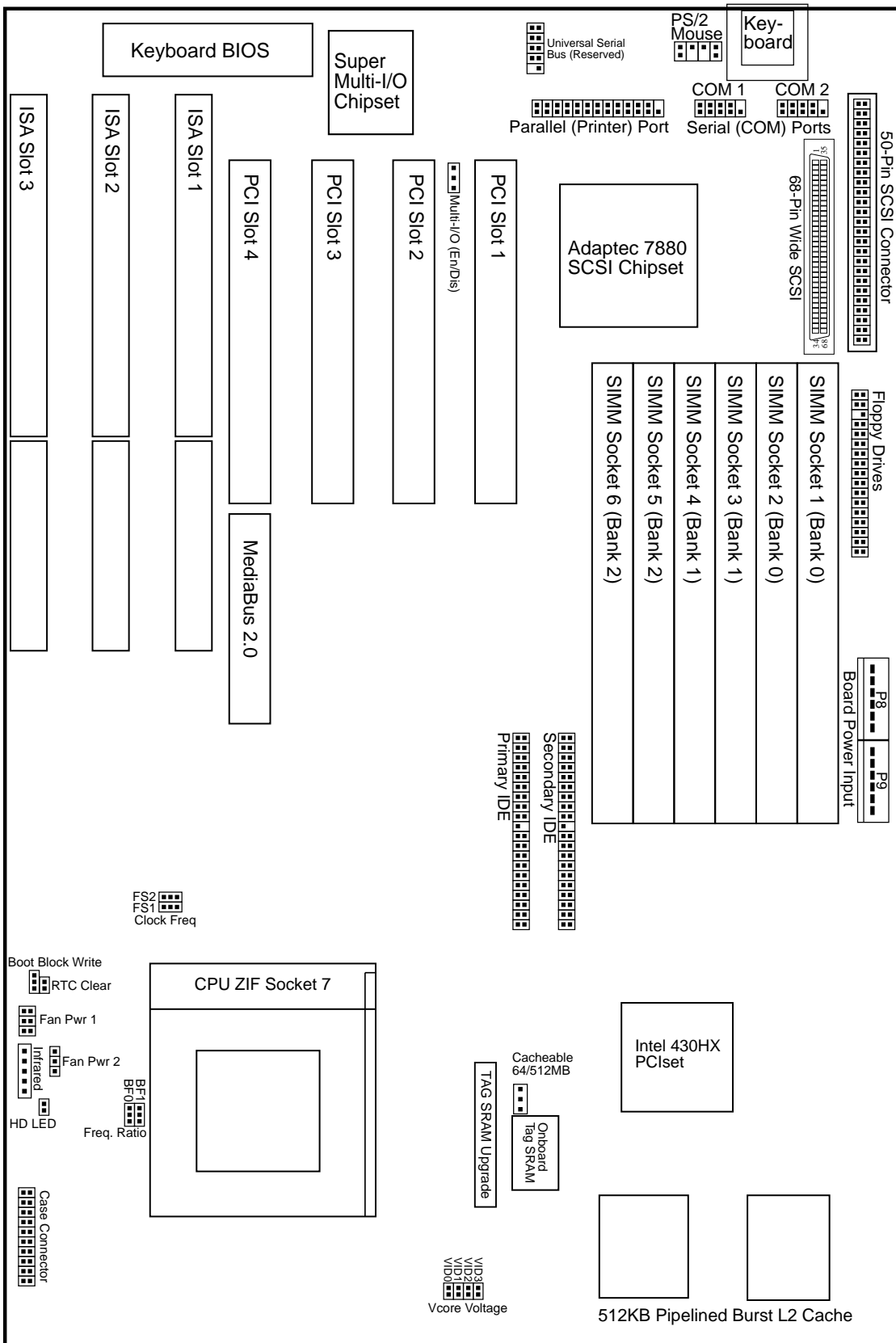

**III. INSTALLATION**  
(Map of Board)

# III. INSTALLATION

---

## Jumpers

1) CBSIZE	p. 7	Memory Cacheable Size (64MB / 512MB)
2) BBLKW	p. 8	Flash ROM Boot Block Program (Disable/Enable)
3) SIO	p. 8	Super Multi-I/O Selection (Enable/Disable)
4) RTCLR	p. 9	Real Time Clock RAM (Operation/Clear Data)
5) FS1, FS2	p. 10	CPU External Clock (BUS) Frequency Selection
6) BF0, BF1	p. 10	CPU:BUS Frequency Ratio (1.5, 2.0, 2.5, 3.0)
7) VID	p. 11	CPU Voltage Selection

## Expansion Slots

1) TAG SRAM	p. 7	TAG SRAM Upgrade Socket
2) SIMM Sockets	p. 12	DRAM Memory Expansion Sockets
3) CPU ZIF Socket 7	p. 15	Central Processing Unit (CPU) Socket
4) ISA Slots 1, 2, 3	p. 16	16-bit ISA Bus Expansion Slots
5) PCI Slots* 1, 2, 3	p. 16	32-bit PCI Bus Expansion Slots
6) PCI 4 / MediaBus	p. 18	32-bit PCI Bus Slot and MediaBus

## Connectors

1) KBCON	p. 18	Keyboard Connector (5-pin Female)
2) PS2MOUSE	p. 18	PS/2 Mouse Connector (6-pin Block)
3) PRINTER	p. 19	Parallel (Printer) Port Connector (26-pin Block)
4) COM1, COM2	p. 19	Serial Port COM1 & COM2 (10-pin Blocks)
5) FLOPPY	p. 20	Floppy Drive Connector (34-pin Block)
6) POWER	p. 20	Motherboard Power Connector (12-pin Block)
7) Primary/Second. IDE	p. 21	Primary/Secondary IDE Connectors (40-pin Blocks)
8) HDLED	p. 21	SCSI/IDE Activity LED Lead
9) TB LED (PANEL)	p. 22	Turbo LED/Power LED (2-pins)
10) SMI (PANEL)	p. 22	SMI Switch Lead (2-pins)
11) RESET (PANEL)	p. 22	Reset Switch Lead (2-pins)
12) KEYLOCK (PANEL)	p. 22	Keyboard Lock Switch Lead (5-pins)
13) SPEAKER (PANEL)	p. 22	Speaker Connector (4-pins)
14) FANPWR 1, 2	p. 23	12 Volt CPU Cooling Fan Connector
15) IR	p. 23	Infrared Port Module Connector
16) SCSI & Wide SCSI	p. 24	50-Pin SCSI and 68-Pin Wide-SCSI Connectors

**\* PCI Slot 1 share the same interrupt number (INTA#) with the onboard 7880 SCSI chipset, therefore PCI Slot 1 cannot use expansion cards which require an interrupt number. Use the other PCI Slots first. If you need all the slots, try using your display card on PCI Slot 1 because some display cards do not use an interrupt number.**







# III. INSTALLATION

## Installation Steps

Before using your computer, you must complete the following steps:

1. Set Jumpers on the Motherboard
2. Install DRAM Modules
3. Install the Central Processing Unit (CPU)
4. Install Expansion Cards
5. Connect Ribbon Cables, Cabinet Wires, and Power Supply
6. Setup the BIOS Software

### 1. Jumpers

Several hardware settings are made through the use of jumper caps to connect jumper pins (JP) on the motherboard. See "Map of the Motherboard" on page 4 for locations of jumpers. The jumper settings will be described numerically such as [----], [1-2], [2-3] for no connection, connect pins 1&2, and connect pins 2&3 respectively. Pin 1 for our motherboards is always on top  or on the left  when holding the motherboard with the keyboard connector away from yourself. A "1" is written besides pin 1 on jumpers with three pins. The jumpers will also be shown graphically such as  to connect pins 1&2 and  to connect pins 2&3. Jumpers with two pins will be shown as  for Short (On) and  for Open (Off). For manufacturing simplicity, the jumpers may be sharing pins from other groups. Use the diagrams in this manual instead of following the pin layout on the board. Settings with two jumper numbers require that both jumpers be moved together. To connect the pins, simply place a plastic jumper cap over the two pins as diagramed.

**WARNING:** Computer motherboards and components contain very delicate Integrated Circuit (IC) chips. To protect the motherboard and other components against damage from static electricity, you should follow some precautions whenever you work on your computer.

1. Unplug your computer when working on the inside.
2. Hold components by the edges and try not to touch the IC chips, leads, or circuitry.
3. Use a grounded wrist strap before handling computer components.
4. Place components on a grounded antistatic pad or on the bag that came with the component whenever the components are separated from the system.

# III. INSTALLATION

## Jumper Settings

### 1. Memory Cacheable Size (CBSIZE)

The default of **64MB** uses only the onboard TAG SRAM which allows cacheable memory up to 64MB. If you install DRAM above 64MB and wish to allow cacheable memory above 64MB, you need to install a TAG SRAM upgrade and set this jumper to **512MB**. See this section for "TAG SRAM Upgrade."

<u>Cacheable Size</u>	<u>CBSIZE</u>
64MB	[1-2] (Default)
512MB	[2-3]

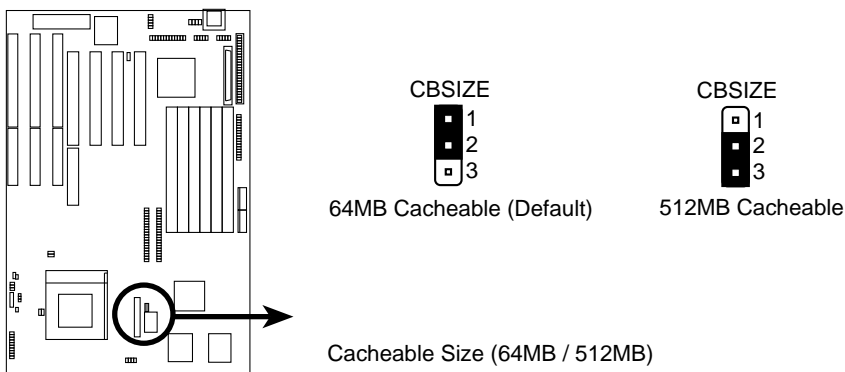

## TAG SRAM Upgrade

The purpose of this SRAM is described by "Memory Cacheable Size" jumper. You must use a standard 5Volt SRAM chip that is 15ns or faster.

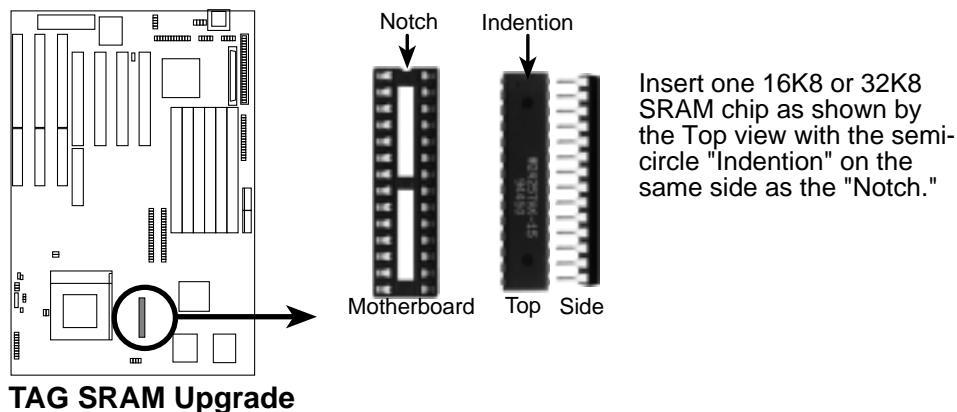

# III. INSTALLATION

## 2. Flash ROM Boot Block Programming (BBLKW)

This sets the operation mode of the boot block area of the Programmable Flash ROM to allow programming in the *Enabled* position. This is required only if prompted by the **Flash Memory Writer Utility** as shown in BIOS SOFTWARE.

<u>Programming</u>	<u>BBLKW</u>
Disabled	[1-2] (Default)
Enabled	[2-3]

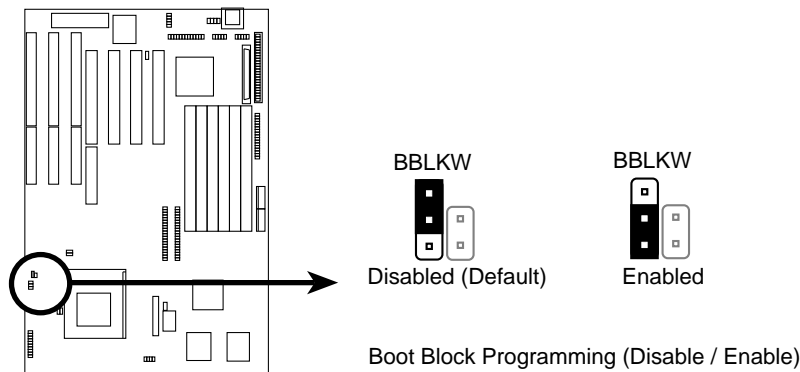

## 3. Onboard Multi-I/O Selection (SIO)

You can selectively disable each onboard Multi-I/O item (floppy, serial, parallel, and IrDA) through **Chipset Features Setup** of BIOS SOFTWARE *or* disable all Multi-I/O items at once with the following jumper in order to use your own Multi-I/O card.

<u>Selections</u>	<u>SIO</u>
Enable	[1-2] (Default)
Disable	[2-3]

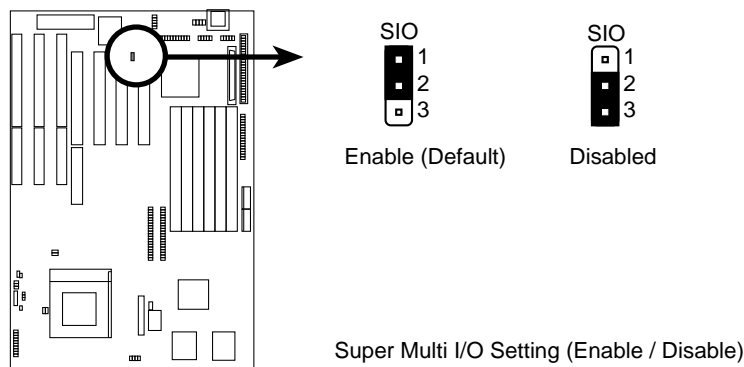

# III. INSTALLATION

## 4. Real Time Clock (RTC) RAM (RTCLR)

This clears the user-entered information stored in the CMOS RAM of the Real Time Clock such as hard disk information and passwords. To clear the RTC data: (1) Turn off the PC, (2) Short this jumper, (3) Power on the PC, (4) Turn off the PC, (5) Remove this jumper, (6) Power on the PC, (7) Hold down <Delete> during bootup and enter BIOS setup to re-enter user preferences.

### Selections **RTCLR**

Operation [open] (Default)

Clear Data [short] (momentarily)

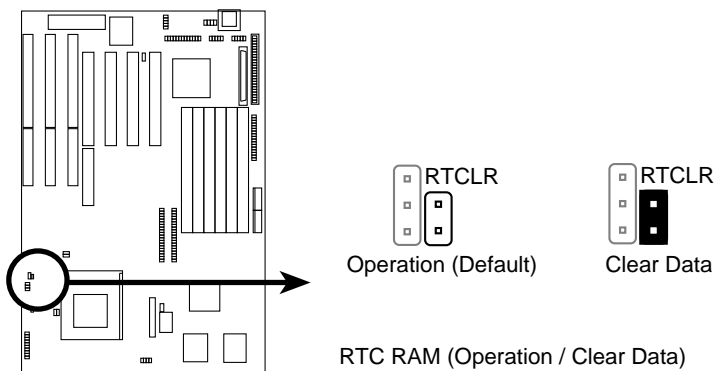

# III. INSTALLATION

## 5. CPU External (BUS) Frequency Selection (FS1, FS2)

These jumpers tells the clock generator what frequency to send to the CPU. These allow the selection of the CPU's *External* frequency (or *BUS Clock*). The *BUS Clock* times the *BUS Ratio* equals the CPU's *Internal* frequency (the advertised CPU speed).

## 6. CPU to BUS Frequency Ratio (BF0, BF1)

These jumpers set the frequency ratio between the *Internal* frequency of the CPU and the *External* frequency (called the *BUS Clock*) within the CPU. These must be set together with the above jumpers *CPU External (BUS) Frequency Selection*.

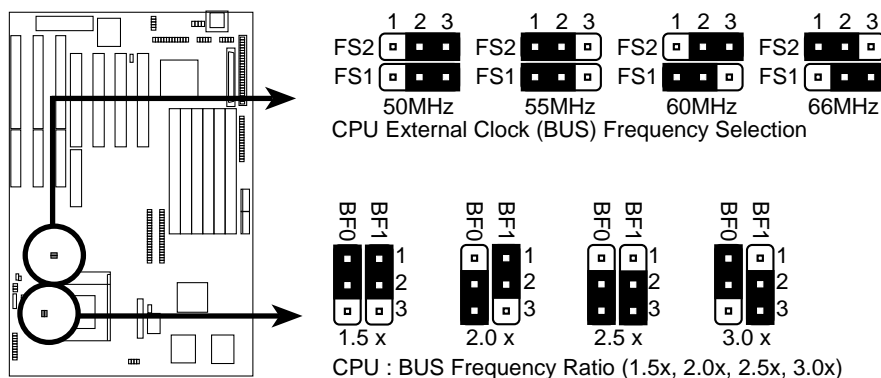

Set the jumpers by the Internal speed of the Intel, Cyrix, or AMD CPU as follows:

CPU Model	Freq.	Ratio	(BUS Freq.)	(BUS Frequency)		(Freq. Ratio)	
				FS2	FS1	BF0	BF1
Intel Pentium	200MHz	3.0x	66MHz	[1-2]	[2-3]	[1-2]	[2-3]
Intel Pentium	166MHz	2.5x	66MHz	[1-2]	[2-3]	[2-3]	[2-3]
Intel Pentium	150MHz	2.5x	60MHz	[2-3]	[1-2]	[2-3]	[2-3]
Intel Pentium	133MHz	2.0x	66MHz	[1-2]	[2-3]	[2-3]	[1-2]
Intel Pentium	120MHz	2.0x	60MHz	[2-3]	[1-2]	[2-3]	[1-2]
Intel Pentium	100MHz	1.5x	66MHz	[1-2]	[2-3]	[1-2]	[1-2]
Intel Pentium	90MHz	1.5x	60MHz	[2-3]	[1-2]	[1-2]	[1-2]
Intel Pentium	75MHz	1.5x	50MHz	[2-3]	[2-3]	[1-2]	[1-2]
Cyrix 166+	133MHz	2.0x	66MHz	[1-2]	[2-3]	[2-3]	[1-2]
AMD	100MHz	1.5x	66MHz	[1-2]	[2-3]	[1-2]	[1-2]
AMD	90MHz	1.5x	60MHz	[2-3]	[1-2]	[1-2]	[1-2]
AMD	75MHz	1.5x	50MHz	[2-3]	[2-3]	[1-2]	[1-2]



# III. INSTALLATION

## Cyrix CPU Identification

The Cyrix CPU that is supported on this motherboard is labeled Cyrix 6x86 P166+ but must be Revision 2.7 and later. Look on the underside of the CPU for the serial number. The number should read G8DC6620A or larger.

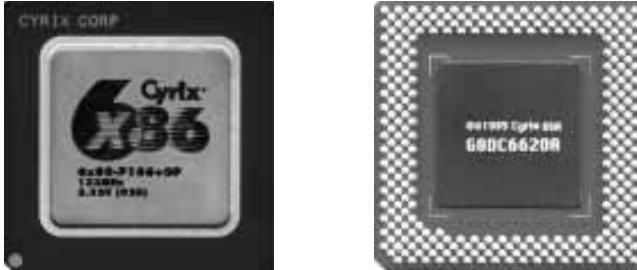

### 7. CPU Voltage Regulator Selection (VID)

These jumpers set the voltage supplied to the CPU. Currently Intel's new Pentium P55C 200MHz is now supported at 2.8Volts.

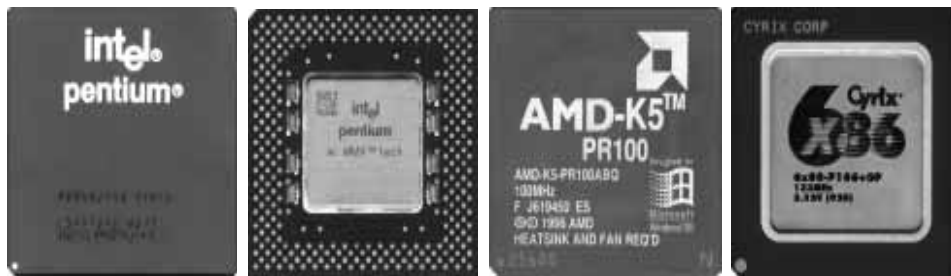

Intel P54C Pentium (75-200MHz)    Intel P55C Pentium MMX (200MHz)    AMD-K5 (PR75-100MHz)    Cyrix 6x86 166+ Rev2.7 (133MHz)

#### Single Power Plane

	<u>VID0</u>	<u>VID1</u>	<u>VID2</u>	<u>VID3</u>
2.9 Volts (VRE)	[short]	[open]	[open]	[open]
2.8 Volts (STD-Default)	[open]	[short]	[open]	[open]
2.7 Volts	[open]	[open]	[short]	[open]
2.5 Volts	[open]	[open]	[open]	[short]

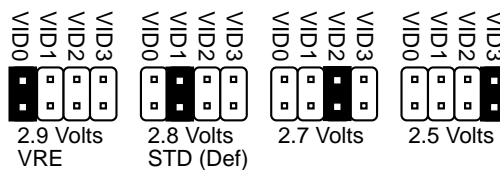
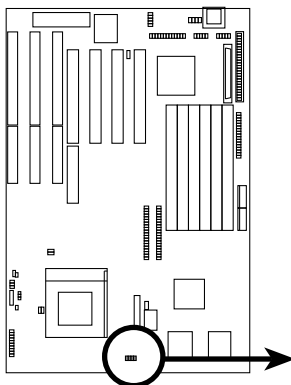

CPU Vcore Voltage Selection

III. INSTALLATION (Jumpers)

# III. INSTALLATION

## 2. System Memory (DRAM & SRAM)

This motherboard supports six 72-pin SIMMs of 4MB, 8MB, 16MB, 32MB, or 64MB to form a memory size between 8MB to 256MB. The DRAM can be either 60ns or 70ns Fast Page Mode (Asymmetric or Symmetric) or EDO. To support ECC, you must use *true* (opposed to phantom parity generated by logic chips) 36-bit parity-type DRAM (e.g. 8 chips + 4 parity chips) in pairs for all modules. Mixing 32-bit non-parity DRAM (e.g. 8 chips) and 36-bit DRAM (e.g. 12 chips) will work minus the ECC feature.

*Install memory in any or all of the banks in any combination as follows:*

Bank	Memory Module		Total Memory
Bank 0 SIMM Sockets 1&2	4MB, 8MB, 16MB, 32MB, 64MB 72-pin FPM, EDO, BEDO SIMM	x2	
Bank 1 SIMM Sockets 3&4	4MB, 8MB, 16MB, 32MB, 64MB 72-pin FPM, EDO, BEDO SIMM	x2	
Bank 2 SIMM Sockets 5&6	4MB, 8MB, 16MB, 32MB, 64MB 72-pin FPM, EDO, BEDO SIMM	x2	
Total System Memory (384MB Max)		=	

**IMPORTANT:** Memory setup is required using "Auto Configuration" in Chipset Features Setup of the BIOS SOFTWARE.

**IMPORTANT:** Each bank must have the same size memory installed in pairs. Do not use memory modules with more than 24 chips per module. Modules with more than 24 chips exceed the design specifications of the memory sub-system and will be unstable.

# III. INSTALLATION

## DRAM Memory Installation Procedures:

1. The SIMM memory modules will only fit in one orientation as shown because of a "Plastic Safety Tab" on one end of the SIMM sockets which requires the "Notched End" of the SIMM memory modules.

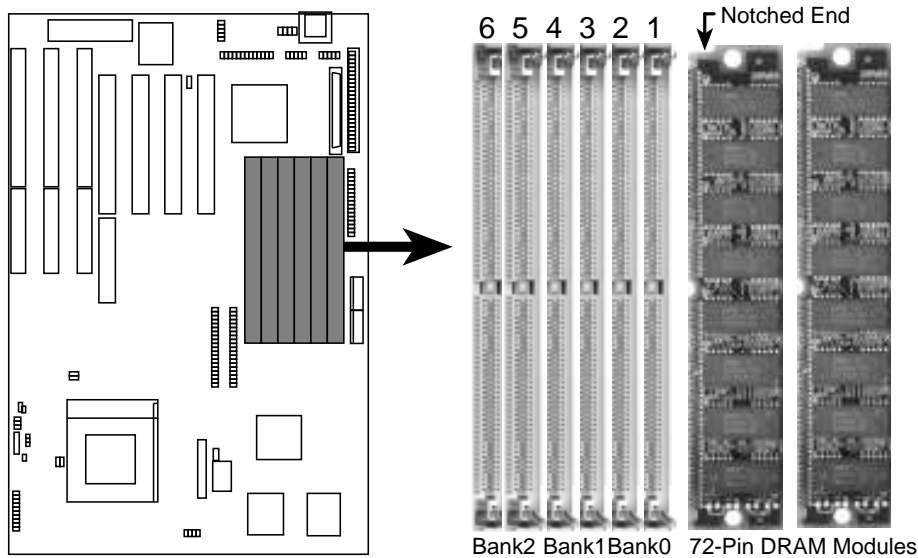

### 72 Pin SIMM DRAM Sockets

2. Press the memory module firmly into place starting from a 45 degree angle making sure that all the contacts are aligned with the socket.
3. With your finger tips, rock the memory module into a vertical position so that it clicks into place.

### 72 Pin DRAM in SIMM Socket

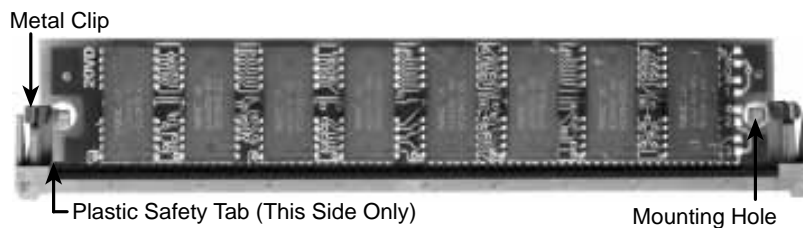

4. The plastic guides should go through the two "Mounting Holes" on the sides and the "Metal Clips" should snap on the other side.
5. To release the memory module, squeeze both "Metal Clips" outwards and rock the module out of the "Metal Clips".

---

(This page was intentionally left blank)

# III. INSTALLATION

## 3. Central Processing Unit (CPU)

The motherboard provides a 321-pin ZIF Socket 7 that is backwards compatible with ZIF Socket 5 processors. The CPU that came with the motherboard should have a fan attached to it to prevent overheating. If this is not the case then purchase a fan before you turn on your system. Apply thermal jelly to the CPU top and then install the fan onto the CPU.

**WARNING:** Without a fan circulating air on the CPU and heat sinks, the CPU and/or heat sinks can overheat and cause damage to both the CPU and the motherboard. (See "CPU Cooling Fan Connector" at the end of this section.)

To install a CPU, first turn off your system and remove its cover. Locate the ZIF socket and open it by first pulling the lever sideways away from the socket then upwards to a 90-degree right angle. Insert the CPU with the correct orientation as shown. Use the notched corner of the CPU with the white dot as your guide. The white dot should point towards the end the of the lever. Notice that there is a blank area where one hole is missing from that corner of the square array of pin holes and a "1" printed on the motherboard next to that corner. Because the CPU has a corner pin for three of the four corners, the CPU will only fit in the one orientation as shown. The picture is for reference only; you should have a CPU fan that will cover the face of the CPU. With the added weight of the CPU fan, no force is required to insert the CPU. Once completely inserted, hold down on the fan and close the socket's lever.

**IMPORTANT:** You must set jumpers for "CPU to BUS Frequency Ratio" and jumpers for "BUS Frequency Selection" depending on the CPU that you install.

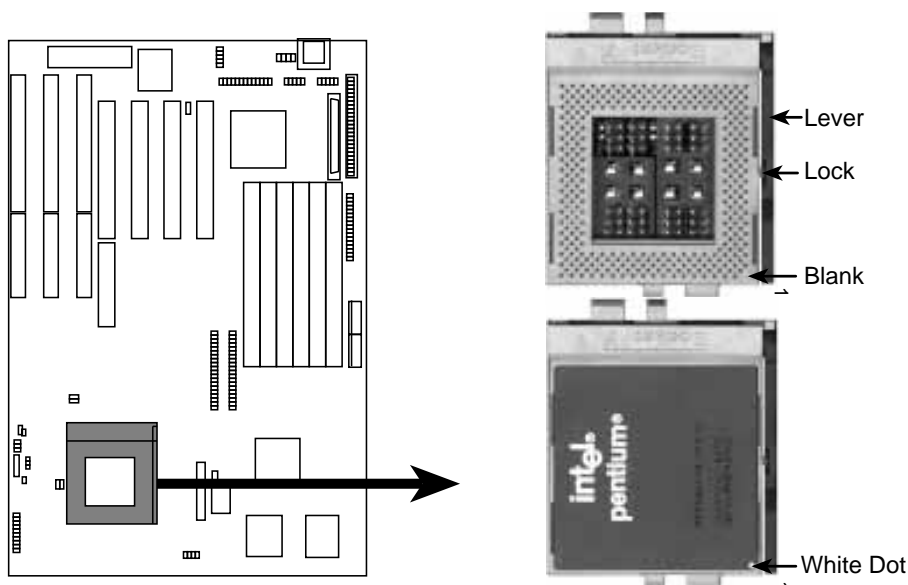

ZIF Socket 7 with Pentium Processor

# III. INSTALLATION

---

## 4. Expansion Cards

**WARNING:** Make sure that you unplug your power supply when adding or removing expansion cards or other system components. Failure to do so may cause severe damage to both your motherboard and expansion cards.

**IMPORTANT:** PCI Slot 1 share the same interrupt number (INTA#) with the onboard 7880 SCSI chipset, therefore PCI Slot 1 cannot use expansion cards which require an interrupt number. Use the other PCI Slots first. If you need all the slots, try using your display card on PCI Slot 1 because some display cards do not use an interrupt number.

First read your expansion card documentation on any hardware and software settings that may be required to setup your specific card.

**NOTE:** PCI Slot 4 has a MediaBus extension 2.0 which allows the installation of a PCI card or a MediaBus card (optional multifunctional card) but not both.

### *Expansion Card Installation Procedure:*

1. Read the documentation for your expansion card.
2. Set any necessary jumpers on your expansion card.
3. Remove your computer system's cover.
4. Remove the bracket on the slot you intend to use. Keep the bracket for possible future use.
5. Carefully align the card's connectors and press firmly.
6. Secure the card on the slot with the screw you removed in step 4.
7. Replace the computer system's cover.
8. Setup the BIOS if necessary (such as "IRQ xx Used By ISA: Yes" in PNP AND PCI SETUP)
9. Install the necessary software drivers for your expansion card.

### *Assigning IRQs for Expansion Cards*

Some expansion cards need to use an IRQ to operate. Generally an IRQ must be exclusively assigned to one use. In an standard design there are 16 IRQs available but most of them are already in use by parts of the system which leaves 6 free for expansion cards.

# III. INSTALLATION

---

Both ISA and PCI expansion cards may need to use IRQs. System IRQs are available to cards installed in the ISA expansion bus first, and any remaining IRQs are then used by PCI cards. Currently, there are two types of ISA cards. The original ISA expansion card design, now referred to as "Legacy" ISA cards, requires that you configure the card's jumpers manually and then install it in any available slot on the ISA bus. You may use Microsoft's Diagnostic (MSD.EXE) utility included in the Windows directory to see a map of your used and free IRQs. For Windows 95 users, the "Control Panel" icon in "My Computer," contains a "System" icon which gives you a "Device Manager" tab. Double clicking on a specific device give you "Resources" tab which shows the Interrupt number and address. Make sure that no two devices use the same IRQs or your computer will experience problems when those two devices are in use at the same time.

To simplify this process this motherboard has complied with the Plug and Play (PNP) specification which was developed to allow automatic system configuration whenever a PNP-compliant card is added to the system. For PNP cards, IRQs are assigned automatically from those available.

If the system has both Legacy and PNP ISA cards installed, IRQs are assigned to PNP cards from those not used by Legacy cards. The PCI and PNP configuration of the BIOS setup utility can be used to indicate which IRQs are being used by Legacy cards. For older Legacy cards that does not work with the BIOS, you can contact your vendor for an ISA Configuration Utility.

An IRQ number is automatically assigned to PCI expansion cards after those used by Legacy and PNP ISA cards. In the PCI bus design, the BIOS automatically assigns an IRQ to a PCI slot that has a card in it that requires an IRQ. To install a PCI card, you need to set something called the INT (interrupt) assignment. Since all the PCI slots on this motherboard use an INTA #, be sure that the jumpers on your PCI cards are set to INT A.

## *Assigning DMA Channels for ISA Cards*

Some ISA cards, both Legacy and PNP may also need to use a DMA (Direct Memory Access) channel. DMA assignments for this motherboard are handled the same way as the IRQ assignment process described above. You can select a DMA channel in the PCI and PNP configuration section of the BIOS Setup utility.

**IMPORTANT: Choose "Yes" for those IRQ's and DMA's you wish to reserve for Legacy (Non-PnP) ISA expansion cards in "IRQ xx Used By ISA" and "DMA x Used By ISA" of the PNP and PCI Setup in the BIOS SOFTWARE section, otherwise conflicts may occur.**

# III. INSTALLATION

## 5. External Connectors

**WARNING:** Some pins are used for connectors or power sources. These are clearly separated from jumpers in "Map of the Motherboard" on page 4. Placing jumper caps over these will cause damage to your motherboard.

**IMPORTANT:** Ribbon cables should always be connected with the red stripe on the Pin 1 side of the connector. The four corners of the connectors are labeled on the motherboard. Pin 1 is the side closest to the power connector on hard drives and floppy drives. IDE ribbon cable must be less than 18in. (46cm), with the second drive connector no more than 6in. (15cm) from the first connector.

### 1. Keyboard Connector (5-pin female)

This connection is for a standard IBM-compatible keyboard. May also be known as a 101 enhanced keyboard.

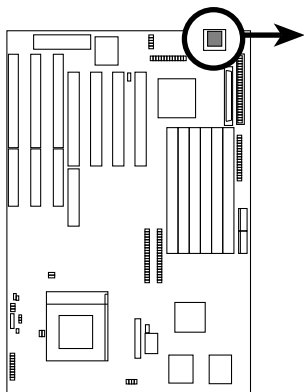

Keyboard Connector



Keyboard Connector (5-pin female)



This motherboard accepts an AT Keyboard Connector Plug as shown here.

### 2. PS/2 Mouse Connector (6-pin block)

If you are using a PS/2 mouse, you must purchase an optional PS/2 mouse set which connects to the 6 pin block and mounts to an open slot on your computer's case. The system will direct IRQ12 to the PS/2 mouse if one is detected. If not detected, expansion cards can use IRQ12. See "PS/2 Mouse Control" in **BIOS Features Setup** of the BIOS SOFTWARE section.

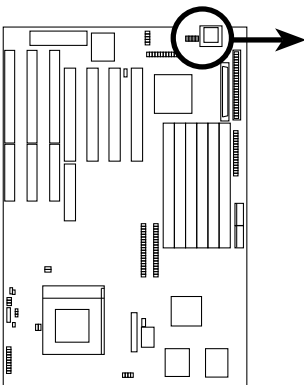

PS/2 Mouse Module Connector

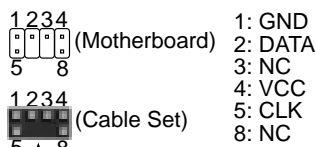

This optional PS/2 mouse cable and bracket set is necessary to provide a connector for a PS/2 mouse on a free expansion slot cover.





# III. INSTALLATION

## 3. Parallel Printer Connector (26 Pin Block)

Connection for the included parallel port ribbon cable with mounting bracket. Connect the ribbon cable to this connection and mount the bracket to the case on an open slot. It will then be available for a parallel printer cable. You can enable the parallel port and choose the IRQ through "Onboard Parallel Port" in **Chipset Features** of the BIOS SOFTWARE. **(Pin 26 is removed to prevent inserting in the wrong orientation when using ribbon cables with pin 26 plugged).**

**NOTE:** Serial printers must be connected to the serial port.

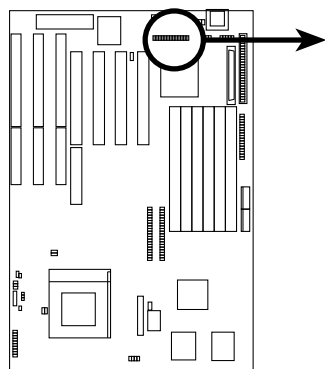

Pin 1

For this connector to be available, you must connect the included Parallel (25-Pin female) cable set to a free expansion slot opening.

**TIP:** You may also remove the bracket connectors and mount them directly to the case to save expansion slot space.

**Onboard Parallel (Printer) Connector**

## 4. Serial Port COM1 and COM2 Connectors (Two 10-pin blocks)

These connectors support the provided serial port ribbon cables with mounting bracket. Connect the ribbon cables to these connectors and mount the bracket to the case on an open slot. The two serial ports on the mounting bracket will then be used for pointing devices or other serial devices. See "Onboard Serial Port" in **Chipset Features Setup**. **(Pin 10 is removed to prevent inserting in the wrong orientation when using ribbon cables with pin 10 plugged).**

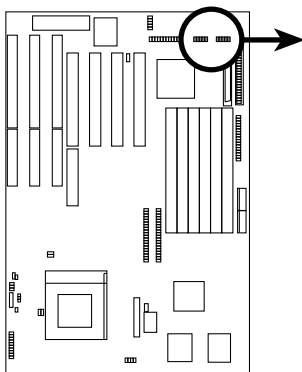

COM 1

Pin 1



COM 2

Pin 1

For these connectors to be available, you must connect the included Serial cable set from COM1 (using the 9-Pin male) & COM2 (using the 25-Pin male) to a free expansion slot opening.

**TIP:** You may also remove the bracket connectors and mount them directly to the case to save expansion slot space.

**Onboard Serial Port Connectors**

# III. INSTALLATION

## 5. Floppy Drive Connector (34-pin block )

This connector supports the provided floppy drive ribbon cable. After connecting the single end to the board, connect the two plugs on the other end to the floppy drives. **(Pin 5 is removed to prevent inserting in the wrong orientation when using ribbon cables with pin 5 plugged).**

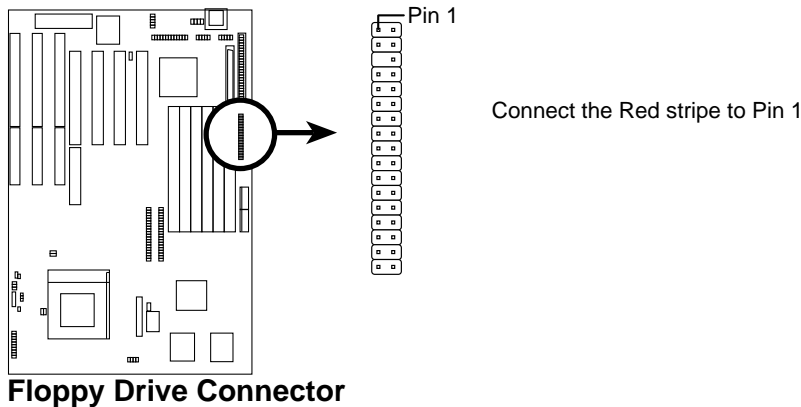

## 6. Power Connector (12-pin block)

This connector connects to a standard 5 Volt power supply. To connect the leads from the power supply, ensure first that the power supply is not plugged. Most power supplies provide two plugs (P8 and P9), each containing six wires, two of which are black. Orient the connectors so that the black wires are located in the middle.

Using a slight angle, align the plastic guide pins on the lead to their receptacles on the connector. Once aligned, press the lead onto the connector until the lead locks into place.

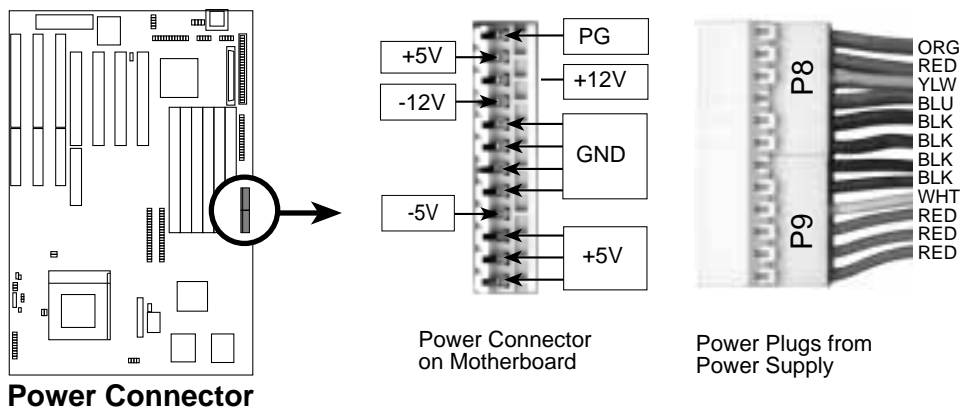

# III. INSTALLATION

## 7. Primary / Secondary IDE Connectors (Two 40-pin Block)

These connectors support the provided IDE hard disk ribbon cable. After connecting the single end to the board, connect the two plugs at the other end to your hard disk(s). If you install two hard disks, you must configure the second drive to Slave mode by setting its jumper accordingly. Please refer to the documentation of your hard disk for the jumper settings. BIOS now supports SCSI device or IDE CD-ROM bootup (see "HDD Sequence SCSI/IDE First" & "Boot Sequence" in the **BIOS Features Setup** of the BIOS SOFTWARE) (**Pin 20 is removed to prevent inserting in the wrong orientation when using ribbon cables with pin 20 plugged**).

**TIP:** You may configure two hard disks to be both Masters using one ribbon cable on the primary IDE connector and another ribbon cable on the secondary IDE connector. You may install one operating system on an IDE drive and another on a SCSI drive and select the boot disk through BIOS Features Setup.

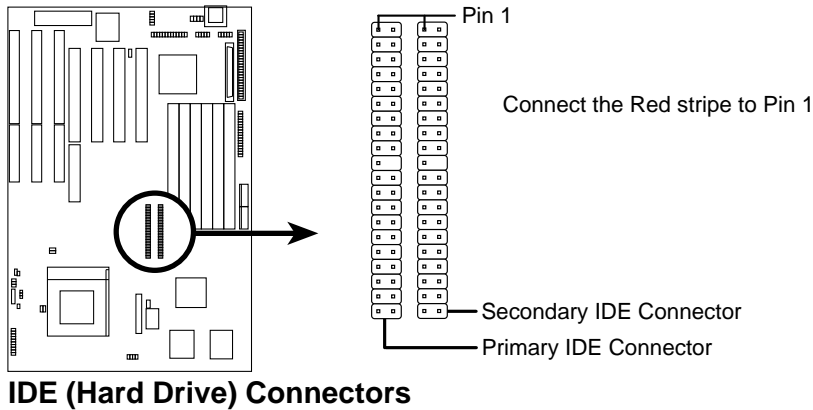

## 8. IDE Activity LED (HDLED)

This 2-Pin lead will light up a case LED whenever there is read/write activity by devices connected to the IDE and/or SCSI connectors.

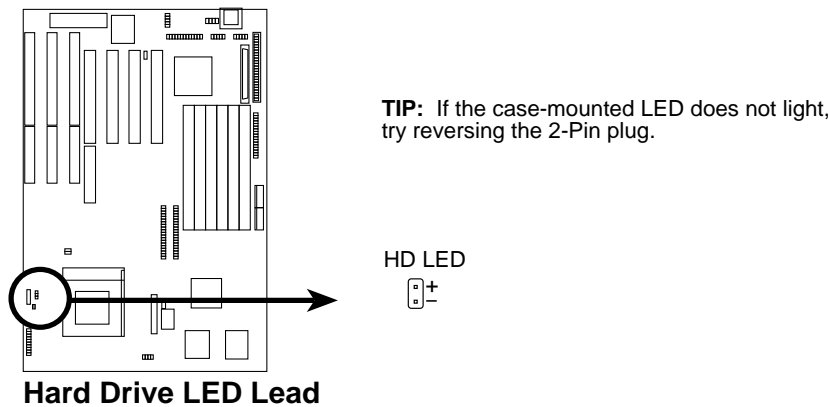

# III. INSTALLATION

## 9. Turbo LED Lead (PANEL)

The motherboard's turbo function is always on. The turbo LED connection is labeled here but the LED will remain constantly lit while the system power is on. You may wish to connect the Power LED from the system case to this lead. See the figure below.

## 10. SMI Suspend Switch Lead (PANEL)

This allows the user to manually place the system into a suspend mode or "Green" mode where system activity will be instantly decreased to save electricity and expand the life of certain components when the system is not in use. This 2-pin connector (see the figure below) connects to the case-mounted suspend switch. If you do not have a switch for the connector, you may use the "Turbo Switch" since it does not have a function. SMI is activated when it detects a *short to open* moment and therefore leaving it shorted will not cause any problems. May require one or two pushes depending on the position of the switch. Wake-up can be controlled by settings in the BIOS but the keyboard will always allow wake-up (the SMI lead cannot wake-up the system). If you want to use this connector, "Suspend Switch" in the **Power Management Setup** of the BIOS SOFTWARE section should be on the default setting of *Enable*.

## 11. Reset Switch Lead (PANEL)

This 2-pin connector connects to the case-mounted reset switch for rebooting your computer without having to turn off your power switch. This is a preferred method of rebooting in order to prolong the life of the system's power supply. See the figure below.

## 12. Keyboard Lock Switch Lead & System Power LED (PANEL)

This 5-pin connector connects to the case-mounted keyboard lock switch for locking the keyboard and also to connect the system power LED. The system power LED lights when the system is powered on. See the figure below.

## 13. Speaker Connector (PANEL)

This 4-pin connector connects to the case-mounted speaker.

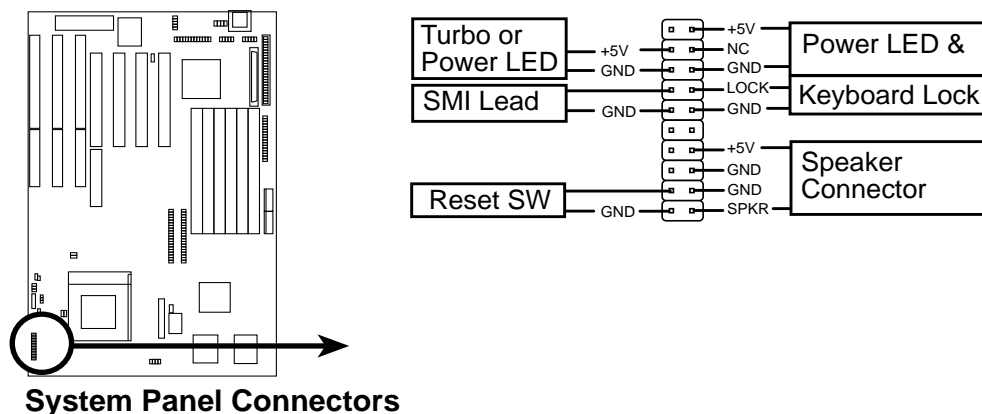

# III. INSTALLATION

## 14. CPU Cooling Fan Connector (FAN)

This connector supports a CPU cooling fan of 500mAMP (6WATT) or less. Orientate the fan so that the heat sink fins allow airflow to go across the onboard heat sink(s) instead of the expansion slots. Depending on the fan manufacturer, the wiring and plug may be different. The red wire should be positive, while the black should be ground. Connect the fan's plug to the board taking into consideration the polarity of the this connector.

**WARNING:** The CPU and/or motherboard will overheat if there is no airflow across the CPU and onboard heatsinks. Damage may occur to the motherboard and/or the CPU fan if these pins are incorrectly used. **These are not jumpers, do not place jumper caps over these pins.**

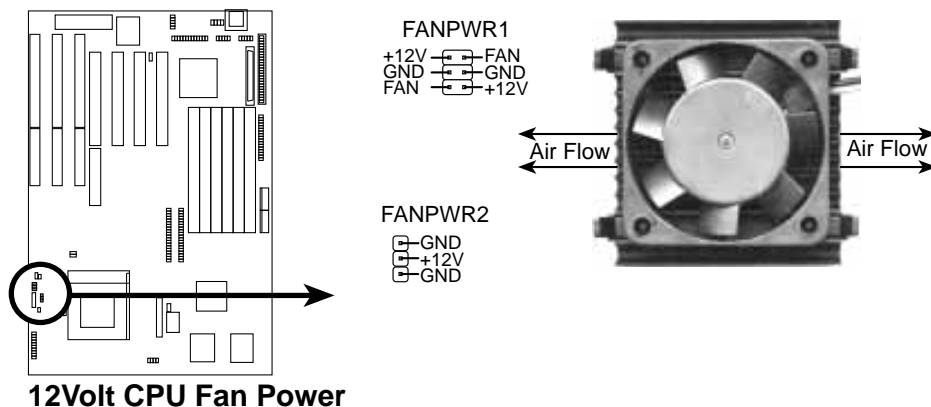

## 15. IrDA-Compliant Infrared Module Connector (IR)

This connector supports the optional wireless transmitting and receiving infrared module. This module mounts to a small opening on system cases that support this feature. You must also configure the setting through "UART2 Use Infrared" in **Chipset Features Setup** to select whether UART2 is directed for use with COM2 or IrDA. Use the five pins as shown on the Back View and connect a ribbon cable from the module to the motherboard according to the pin definitions.

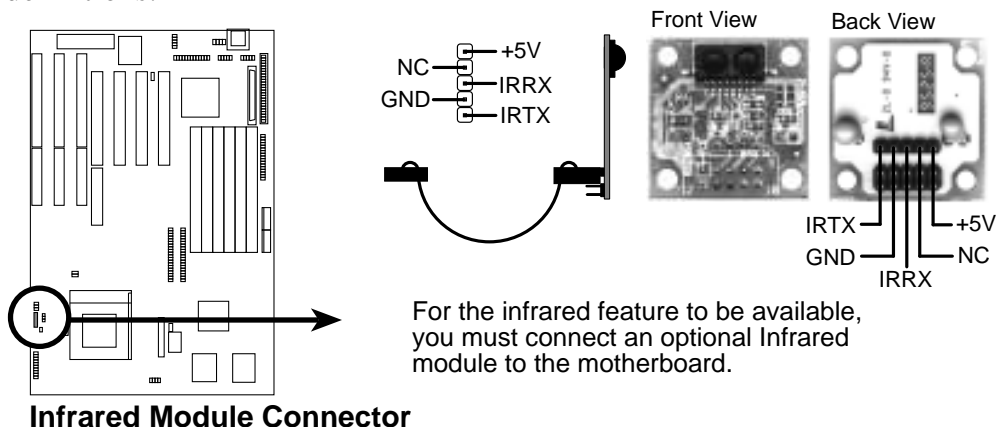

# III. INSTALLATION

## 16. Ultra-Fast SCSI & Ultra-Wide SCSI Connectors

This motherboard has onboard 50-Pin Ultra-Fast SCSI connector for 8-bit SCSI devices and 68-Pin Ultra-Wide SCSI connector for 16-bit SCSI devices.

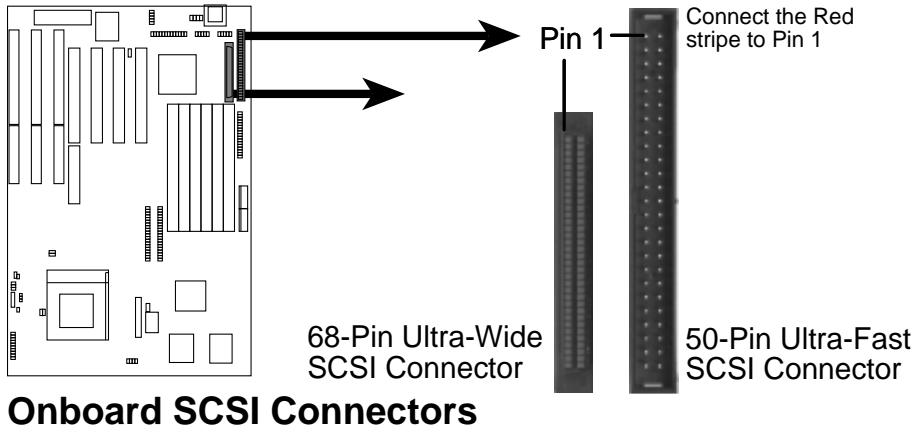

**IMPORTANT:** The 68-Pin Ultra-Wide SCSI Connector is always terminated and will only work as an end device.

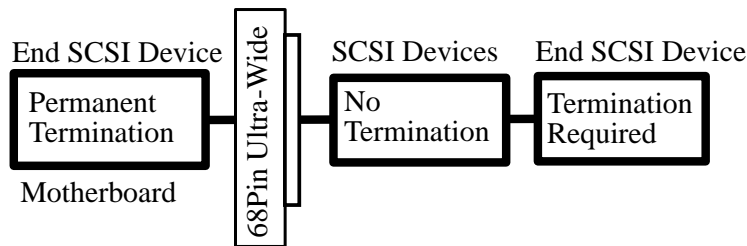

**NOTE:** 50-Pin Fast-SCSI and 68-Pin Ultra-Wide SCSI combined can only have 15 devices among them.

# III. INSTALLATION

---

## Power Connection Procedures

1. After all jumpers and connections are made, close the system case cover.
2. Make sure that all switches are in the off position as marked by ○.
3. Connect the power supply cord into the power supply located on the back of your system case as instructed by your system user's manual.
4. Connect all power cords into a power strip that is equipped by a surge protector.
5. You may then turn on your devices in the following order:
  - a. Your monitor
  - b. External SCSI devices (starting with the last device on the chain)
  - c. Your system power
6. The power LED on the front panel of the system case will light and the monitor LED as well. The system will then run power-on tests. While the tests are running, additional messages will appear on the screen. If you do not see anything within 30 seconds from the time you turn on the power, the system may have failed a power-on test. Recheck your jumper settings and connections or call your authorized dealer for assistance.
7. During power-on, hold down the <Delete> key to enter BIOS setup. Follow the next section "BIOS SOFTWARE" for instructions.

# IV. BIOS SOFTWARE

## Support Software

**FILELIST.TXT** - View this file to see the files included in the support software.

**PFLASH.EXE** - This is the Flash Memory Writer utility that updates the BIOS by uploading a new BIOS file to the programmable flash ROM chip on the motherboard. To determine the BIOS version, check the last four numbers of the code displayed on the upper left-hand corner of your screen during bootup. Larger numbers represent a newer BIOS file.

**NOTE:** A binary BIOS file is no longer included with the support software. Save the motherboard's BIOS file to a floppy diskette as soon as your system is operational. See "Flash Memory Writer Utility" in this section to "Save Current BIOS to File."

## Flash Memory Writer Utility

```
ASUSTeK PNP BIOS
FLASH MEMORY WRITER V1.5
Copyright (C) 1995, ASUSTeK COMPUTER Inc.

Flash Type -- SST 29EE010
Current BIOS Revision: #401A0-xxxx
Choose one of the following:
1. Save Current BIOS To File
2. Update BIOS Main Block From File
3. Advanced Features

Enter Choice: [ 1]

Press ESC To Exit
```

xxxx denotes the current BIOS version stored in the Flash EPROM

**IMPORTANT:** Flash Type may also be "INTEL 28F001BXT." If "unknown" is shown after "Flash type --," then this ROM chip is not programmable or not supported with the PnP BIOS and therefore cannot be programmed by the Flash Memory Writer.

### Main Menu

#### 1. Save Current BIOS to File (Perform as soon as system is operational)

This option allows you to copy the contents of the Flash memory chip onto a diskette. This gives you a backup copy of the original motherboard BIOS in case you need to re-install it.

Create a bootable system floppy diskette by typing [FORMAT A:/S] from the DOS environment without creating "AUTOEXEC.BAT" and "CONFIG.SYS" files, then save the PFLASH.EXE and the BIOS to the floppy diskette.



# IV. BIOS SOFTWARE

---

## 2. Update BIOS Main Block from File

This option updates the BIOS from a file on the disk. This can either be a new file or a backup file created by the "Save Current BIOS to File" option. This will not update the Boot Block if the Boot Block is different. You will be prompted with the following if advanced features if necessary.

```
Boot Block of New BIOS is different from old one !!!  
Please Use 'Advanced Feature' to flash whole bios !!!
```

## 3. Advanced Features

Selecting this option brings up the Advanced Features screen for clearing the PnP configuration record and updating the motherboard BIOS.

### *Advanced Features Menu*

```
Advanced Features  
  
Flash Type -- SST 29EE010  
Current BIOS Revision: #401A0-xxxx  
Choose one of the following:  
1. Clear PNP ESCD Parameter Block  
2. Update BIOS Including Boot Block and ESCD  
  
Enter Choice: [ 2]  
  
Press ESC To Exit
```

xxxx denotes the current BIOS version stored in the Flash EPROM

### 1. Clear PNP ESCD Parameter Block

This option erases the Plug-and-Play (PnP) configuration record.

### 2. Update BIOS Including Boot Block and ESCD

This option updates the Boot Block, the motherboard BIOS and the PnP ESCD Parameter Block from a new BIOS file.

**NOTE:** "Update BIOS Main Block from File" and "Update BIOS Including Boot Block and ESCD" requires that the system is running in real mode. This utility will not operate if the system is under protected mode or virtual mode. You should boot from a system floppy diskette without "AUTOEXEC.BAT" and "CONFIG.SYS" files.

# IV. BIOS SOFTWARE

---

## Updating your Motherboard's BIOS

1. Download an updated BIOS file from Bulletin Board Services (BBS) or the internet (WWW) and save to the diskette you created in step 1 of the Main Menu. See **ASUS CONTACT INFORMATION** on page II.
2. Turn off your computer and open the system cabinet to *Enable* "Boot Block Programming" jumper as shown in section III.
2. Boot from the floppy diskette you created in step 1 of the main menu.
3. At the "A:\\" prompt, type: **PFLASH <Enter>**
4. Enter "2" from the Main Menu or "2" from the Advanced Features Menu.
5. The program displays a second screen prompting you for the name of the BIOS file. Type in the complete name of the file, including the file name extension, and then press the <Enter> key. The utility then uploads the BIOS file from disk. The following message will appear:

**DO NOT TURN OFF THE SYSTEM IF THERE IS A PROBLEM!**

If you encounter problems while downloading the new BIOS, **DO NOT** turn off your system since this might prevent your system from booting up. Just repeat the process, and if the problem still persists, upload the original BIOS file you saved to disk in step 1 of the Main Menu.

**WARNING:** If the Flash Memory Writer utility was not able to successfully download a complete BIOS file, your system may not be able to boot up. If this happens, your system will require service from your vendor.

6. After successfully downloading the new BIOS file, exit the Flash Memory Writer utility and **then turn off your system**. Set the jumper back to its default setting of Programming "*Disabled.*"
7. Turn on your computer and hold down <delete> to enter BIOS setup. **You must select "Setup Default" to affect the new BIOS, then you may set other items from the Main Menu.**

# IV. BIOS SOFTWARE

## 6. BIOS Setup

The motherboard supports two programmable Flash ROM chips: 5 Volt and 12 Volt. Either of these memory chips can be updated when BIOS upgrades are released. Use the Flash Memory Writer utility to download the new BIOS file into the ROM chip as described in detail in this section.

All computer motherboards provide a Setup utility program for specifying the system configuration and settings. If your motherboard came in a computer system, the proper configuration entries may have already been made. If so, invoke the Setup utility, as described later, and take note of the configuration settings for future reference; in particular, the hard disk specifications.

If you are installing the motherboard, reconfiguring your system or you receive a Run Setup message, you will need to enter new setup information. This section describes how to configure your system using this utility.

The BIOS ROM of the system stores the Setup utility. When you turn on the computer, the system provides you with the opportunity to run this program. This appears during the Power-On Self Test (POST). Press the <Delete> key to call up the Setup utility. If you are a little bit late pressing the mentioned key(s), POST will continue with its test routines, thus preventing you from calling up Setup. If you still need to call Setup, reset the system by simultaneously pressing the <Ctrl>, <Alt> and <Delete> keys, or by pushing the Reset button on the system case. You can also restart by turning the system off and then back on again. But do so only if the first two methods fail.

When you invoke Setup, the CMOS SETUP UTILITY main program screen will appear with the following options:



# IV. BIOS SOFTWARE

## Load Defaults

The “Load BIOS Defaults” option loads the minimized settings for troubleshooting. “**Load Setup Defaults**”, on the other hand, is for loading optimized defaults for regular use. Choosing defaults at this level, will modify all applicable settings.

A section at the bottom of the above screen displays the control keys for this screen. Take note of these keys and their respective uses. Another section just below the control keys section displays information on the currently highlighted item in the list.

## Standard CMOS Setup

This “Standard CMOS Setup” option allows you to record some basic system hardware configuration and set the system clock and error handling. If the motherboard is already installed in a working system, you will not need to select this option anymore. However, if the configuration stored in the CMOS memory on the board gets lost or damaged, or if you change your system hardware configuration, you will need to respecify the configuration values. The configuration values usually get lost or corrupted when the power of the onboard CMOS battery weakens.

```
ROM PCI/ISA BIOS (P55T2P4S)
STANDARD CMOS SETUP
AWARD SOFTWARE, INC.

Date (mm:dd:yy) : Thu, Nov 21 1996
Time (hh:mm:ss) : 10 : 13 : 6

HARD DISKS      TYPE  SIZE  CVLS  HEAD  PRECOMP  LANDZ  SECTOR  MODE
-----
Primary Master  : Auto   0      0     0      0       0       0     AUTO
Primary Slave   : None   0      0     0      0       0       0     -----
Secondary Master : Auto   0      0     0      0       0       0     AUTO
Secondary Slave  : None   0      0     0      0       0       0     -----

Drive A : 1.44M, 3.5 in.
Drive B : None
Floppy 3 Mode Support : Disabled

Video : EGA/VGA
Halt On : All Errors

Base Memory: 640K
Extended Memory: 64512K
Other Memory: 384K
-----
Total Memory: 65536K

ESC : Quit          ↑ ↓ → ← : Select Item      PU/PD/+/- : Modify
F1  : Help         (Shift)F2 : Change Color
```

IV. BIOS  
(Standard CMOS)

The above screen provides you with a list of options. At the bottom of this screen are the control keys for use on this screen. Take note of these keys and their respective uses.

User-configurable fields appear in a different color. If you need information on the selected field, press the <F1> key. The help menu will then appear to provide you with the information you need. The memory display at the lower right-hand side of the screen is read-only and automatically adjusts accordingly.

## IV. BIOS SOFTWARE

---

### *Details of Standard CMOS Setup:*

#### **Date**

To set the date, highlight the “Date” field and then press the page up/page down or +/- keys to set the current date. Follow the month, day and year format. Valid values for month, day and year are:

<b>Month:</b>	<b>1 to 12</b>
<b>Day:</b>	<b>1 to 31</b>
<b>Year:</b>	<b>up to 2099</b>

#### **Time**

To set the time, highlight the “Time” field and then press the page up/page down or +/- keys to set the current time. Follow the hour, minute and second format. Valid values for hour, minute and second are:

<b>Hour:</b>	<b>00 to 23</b>
<b>Minute:</b>	<b>00 to 59</b>
<b>Second:</b>	<b>00 to 59</b>

You can bypass the date and time prompts by creating an AUTOEXEC.BAT file. For information on how to create this file, please refer to the MS-DOS manual.

#### **Hard Disk Drives**

This field records the specifications for all non-SCSI hard disk drives installed in your system. The onboard PCI IDE connectors provide Primary and Secondary channels for connecting up to four IDE hard disks or other IDE devices. Each channel can support up to two hard disks; the first of which is the “master” and the second is the “slave”.

Specifications for SCSI hard disks need not to be entered here since they operate using device drivers and are not supported by any the BIOS. If you install other vendor’s SCSI controller card, please refer to their respective documentations on how to install the required SCSI drivers.

# IV. BIOS SOFTWARE

---

## For IDE hard disk drive setup, you can:

- Use the *Auto* setting for detection during bootup.
- Use the IDE HDD AUTO DETECTION in the main menu to automatically enter the drive specifications.
- Enter the specifications yourself manually by using the "User" option.

The entries for specifying the hard disk type include **CYLS** (number of cylinders), **HEAD** (number of read/write heads), **PRECOMP** (write precompensation), **LANDZ** (landing zone), **SECTOR** (number of sectors) and **MODE**. The **SIZE** field automatically adjusts according to the configuration you specify. The documentation that comes with your hard disk should provide you with the information regarding the drive specifications.

The **MODE** entry is for IDE hard disks only, and can be ignored for MFM and ESDI drives. This entry provides three options: *Normal*, *Large*, *LBA*, or *Auto* (see below). Set **MODE** to the *Normal* for IDE hard disk drives smaller than 528MB; set it to *LBA* for drives over 528MB that support Logical Block Addressing (LBA) to allow larger IDE hard disks; set it to *Large* for drives over 528MB that do not support LBA. *Large* type of drive can only be used with MS-DOS and is very uncommon. Most IDE drives over 528MB support the *LBA* mode.

## Auto detection of hard disks on bootup

For each field: Primary Master, Primary Slave, Secondary Master, and Secondary Slave, you can select *Auto* under the TYPE and MODE fields. This will enable auto detection of your IDE drives during bootup. This will allow you to change your hard drives (with the power off) and then power on without having to reconfigure your hard drive type. If you use older hard drives which do not support this feature, then you must configure the hard drive in the standard method as described above by the "User" option.

**NOTE:** After the IDE hard disk drive information has been entered into BIOS, new IDE hard disk drives must be partitioned (such as with FDISK) and then formatted before data can be read from and write on. Primary IDE hard disk drives must have its partition set to *active* (also possible with FDISK).

# IV. BIOS SOFTWARE

---

## Drive A, Drive B

These fields record the types of floppy disk drives installed in your system. The available options for drives A and B are:

*360KB, 5.25 in.*

*1.2MB, 5.25 in.*

*720KB, 3.5 in.*

*1.44MB, 3.5 in.*

*2.88MB, 3.5 in.*

*None*

To enter the configuration value for a particular drive, highlight its corresponding field and then select the drive type using the left- or right-arrow key.

## Floppy 3 Mode Support

This is the Japanese standard floppy drive. The standard stores 1.2MB in a 3.5" diskette. This is normally disabled but you may choose from either:

*Drive A*

*Drive B*

*Both*

*Disabled* (Default)

## Video

Set this field to the type of video display card installed in your system. The options are:

*EGA/VGA* (Default)

*Mono* (for Hercules or MDA)

*CGA 40*

*CGA 80*

If you are using a VGA or any higher resolution card, choose the "EGA/VGA" option.

## Halt On

This field determines which types of errors will cause the system to halt.

*All Errors* (Default)

*No Errors*

*All, But Keyboard*

*All, But Diskette*

*All, But Disk/Key*

# IV. BIOS SOFTWARE

## BIOS Features Setup

This “BIOS Features Setup” option consists of configuration entries that allow you to improve your system performance, or let you set up some system features according to your preference. Some entries here are required by the motherboard’s design to remain in their default settings.

```
ROM PCI/ISA BIOS (P55T2P4S)
BIOS FEATURES SETUP
AWARD SOFTWARE, INC.

Virus Warning           : Disabled
CPU Internal Cache     : Enabled
External Cache         : Enabled
Quick Power On Self Test : Enabled
HDD Sequence SCSI/IDE First: IDE
Boot Sequence          : C, A
Swap Floppy Drive      : Disabled
Boot Up Floppy Seek    : Disabled
Floppy Disk Access Control : R/W
Boot Up NumLock Status : On
Boot Up System Speed   : High
IDE HDD Block Mode Sectors : HDD MAX
Typematic Rate Setting : Disabled
Typematic Rate (Chars/Sec) : 6
Typematic Delay (Msec) : 250
Security Option        : System
PS/2 Mouse Function Control: Auto
PCI/VGA Palette Snoop : Disabled
OS/2 Onboard Memory > 64M : Disabled

Video BIOS Shadow     : Enabled
C8000-CBFFF Shadow    : Disabled
CC000-CFFFF Shadow    : Disabled
D0000-D3FFF Shadow    : Disabled
D4000-D7FFF Shadow    : Disabled
D8000-DBFFF Shadow    : Disabled
DC000-DFFFF Shadow    : Disabled

ESC : Quit           ↑↓←→ : Select Item
F1  : Help           PU/PD/+/- : Modify
F5  : Old Values     (Shift)F2 : Color
F6  : Load BIOS Defaults
F7  : Load Setup Defaults
```

A section at the lower right of the screen displays the control keys you can use. Take note of these keys and their respective uses. If you need information on a particular entry, highlight it and then press the <F1> key. A pop-up help menu will appear to provide you with the information you need. To load the last set values, press the <F5> key. <F6> and <F7> load the BIOS default values and Setup default values, respectively.

### *Details of BIOS Features Setup:*

#### **Virus Warning**

This field protects the boot sector and partition table of your hard disk against accidental modifications. Any attempt to write to them will cause the system to halt and display a warning message. If this occurs, you can either allow the operation to continue or use a bootable virus-free floppy disk to reboot and investigate your system. The default setting is “Disabled”. This setting is recommended because conflicts with new operating systems. Installation of new operating systems require that you disable this to prevent write errors.

#### **CPU Internal Cache**

These fields allow you to *Enable* (default) or *Disable* the CPU’s “Level 1” primary cache. Caching allows better performance.



# IV. BIOS SOFTWARE

---

## External Cache

These fields allow you to *Enable* (default) or *Disable* the CPU's "Level 2" secondary cache. Caching allows better performance.

## Quick Power On Self Test

This field speeds up the Power-On Self Test (POST) routine by skipping retesting a second, third, and fourth time. Setup default setting for this field is *Enabled*. A complete test of the system is done on each test.

## HDD Sequence SCSI/IDE First (New Feature!)

When using both SCSI and IDE hard disk drives, IDE is always the boot disk using drive letter C (default setting of *IDE*). This new feature allows a SCSI hard disk drive to be the boot disk when set to *SCSI*. This allows multiple operating systems to be used on both IDE and SCSI drives or the primary operating system to boot using a SCSI hard disk drive.

## Boot Sequence

This field determines where the system looks first for an operating system. Options are *C,CDROM,A*; *CDROM,C,A*; *A,C*; *C,A*. The setup default setting is to check first the hard disk and then the floppy drive; that is, *C, A*.

## Swap Floppy Drive

When enabled, the BIOS swaps floppy drive assignments so that Drive A becomes Drive B, and Drive B becomes Drive A under DOS. By setup default, this field is set to *Disabled*.

## Boot Up Floppy Seek

When enabled, the BIOS will seek the floppy "A" drive one time. By setup default, this field is set to *Disabled*.

## Floppy Disk Access Control

This allows protection of files from the computer system to be copied to floppy drives by allowing the setting of *Read Only* to only allow reads from the floppy but not writes. The setup default *R/W* allows both reads and writes.

## Boot Up NumLock Status

This field enables users to activate the Number Lock function upon system boot. The setup default setting for this field is *On*.

## Boot Up System Speed

This has no function and should be left at the setup default of *High*.

## IDE HDD Block Mode Sectors

This field enhances hard disk performance by making multi-sector transfers instead of one sector per transfer. Most IDE drives, except older versions, can utilize this feature. By setup default, this field is set to *HDD MAX*, other selections are *Disabled 2, 4, 8, 16, and 32*.

# IV. BIOS SOFTWARE

---

## Typematic Rate Setting

When enabled, you can set the two typematic controls listed next. Setup default setting is *Disabled*.

### Typematic Rate (Chars/Sec)

This field controls the speed at which the system registers repeated keystrokes. Options range from 6 to 30 characters per second. Setup default setting is **6**; other settings are **8, 10, 12, 15, 20, 24, and 30**.

### Typematic Delay (Msec)

This field sets the time interval for displaying the first and second characters. Four delay rate options are available: 250ms, 500ms, 750ms and 1000ms. Setup default value is **250ms**.

## Security Option

This field determines when the system prompts for the password. The default setting is *System*, where the system prompts for the User Password every time you boot up. The other option is *Setup*, where the system always boots up, and prompts for the Supervisor Password only when the Setup utility is called up. You can specify a password by using the *Supervisor Password* or *User Password* option from the main screen as explained later in this section.

## PS/2 Mouse Function Control

The default of *Auto* allows the system to detect a PS/2 Mouse on bootup. If detected, IRQ12 will be used for the PS/2 Mouse. IRQ12 will be reserved for expansion cards if a PS/2 Mouse is not detected. *Disabled* will reserve IRQ12 for expansion cards and therefore the PS/2 Mouse will not function.

## PCI/VGA Palette Snoop

Some display cards that are nonstandard VGA such as graphics accelerators or MPEG Video Cards may not show colors properly. The setting *Enabled* should correct this problem. Otherwise leave this on the setup default setting of *Disabled*.

## OS/2 Onboard Memory > 64M

When using OS/2 operating systems with installed DRAM of greater than 64MB, you need to *Enable* this option otherwise leave this on the setup default of *Disabled*.

.....

## Video BIOS Shadow

This field allows you to change the video BIOS location from ROM to RAM. Relocating to RAM enhances system performance, as information access is faster than the ROM. Setup default setting is *Enabled*.

## C8000-CBFFF to DC000-DFFFF

These fields are used for shadowing other expansion card ROMs. If you install other expansion cards with ROMs on them, you will need to know which addresses the ROMs use to shadow them specifically. Shadowing a ROM reduces the memory available between 640KB and 1024KB by the amount used for this purpose. Leave on default setting of *Disabled*.

# IV. BIOS SOFTWARE

## Chipset Features Setup

This “Chipset Features Setup” option controls the configuration of the board’s chipset. Control keys for this screen are the same as for the previous screen.

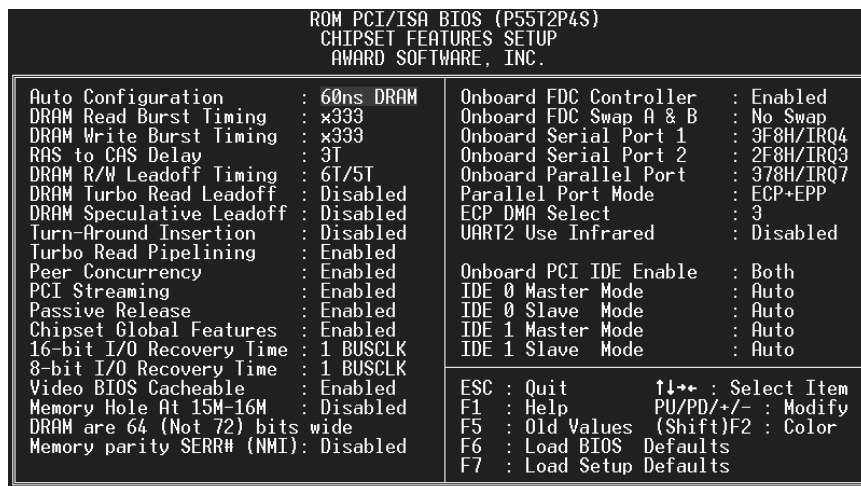

### Auto Configuration

The default setting of **60ns DRAM** sets the optimal timings for items 2 through 9 for 60ns DRAM modules. If you are using 70ns DRAM modules, you must change this item to **70ns DRAM**. See pages 12-13 for DRAM installation information.

**Peer Concurrency** (Leave on default setting of **Enabled**)

**PCI Streaming** (Leave on default setting of **Enabled**)

**Passive Release** (Leave on default setting of **Enabled**)

**Chipset Global Features** (Leave on default setting of **Enabled**)

### 16-bit I/O Recovery Time

Timing for 16-bit ISA cards (Leave on default setting of **1 BUSCLK**)

### 8-bit I/O Recovery Time

Timing for 8-bit ISA cards (Leave on default setting of **1 BUSCLK**)

### Video BIOS Cacheable

Allows the Video BIOS to be cached to allow faster execution. (Leave on default setting of **Enabled**)

### Memory Hole at 15M - 16M

Enabling this features reserves 15MB to 16MB memory address space to ISA expansion cards that specifically require this setting. This makes the memory from 15MB and up unavailable to the system. Expansion cards can only access memory up to 16MB. The default is **Disabled**.

# IV. BIOS SOFTWARE

## [DRAM and ECC]

If all your DRAM modules have parity chips (e.g. 8 chips + 4 parity chips), they are considered 36bits. This motherboard sums the memory per bank and therefore two modules will give 72bits and the following will be displayed:

```
DRAM are 72 bits wide           F5 : Old Values (Shift)F2 : Color
Memory parity SERR# (NMI): Disabled F6 : Load BIOS Defaults
DRAM ECC/PARITY Select : Parity   F7 : Load Setup Defaults
```

If your DRAM modules do not have parity chips (e.g. 8 chips), they are considered 32bits and the following will be displayed instead:

```
DRAM are 64 (Not 72) bits wide F5 : Old Values (Shift)F2 : Color
Memory parity SERR# (NMI): Disabled F6 : Load BIOS Defaults
F7 : Load Setup Defaults
```

The default of *Disabled* for **Memory parity SERR# (NMI)** will not show memory errors on your monitor. When using parity DRAM modules, you can select from the default of *Parity* or *ECC* (Error Checking and Correcting) to correct 1 bit memory errors that may occur in the memory. (See pages 12-13 for more information on DRAM memory modules.)

.....

### Onboard FDC Controller

When enabled, this field allows you to connect your floppy disk drives to the on-board floppy drive connector instead of a separate controller card. If you want to use a different controller card to connect the floppy drives, set this field to “Disabled”. Default setting is *Enabled*.

### Onboard FDC Swap A: B:

This field reverses the drive letter assignments of your floppy disk drives in the *Swap AB* setting, otherwise leave on the default setting of *No Swap*. This works separately from the BIOS Features floppy disk swap feature. It is functionally the same as physically interchanging the connectors of the floppy disk drives.

### Onboard Serial Port 1

Settings are *3F8H/IRQ4* (default), *2F8H/IRQ3*, *3E8H/IRQ4*, *2E8H/IRQ10*, and *Disabled* for the onboard serial connector.

### Onboard Serial Port 2

Settings are *3F8H/IRQ4*, *2F8H/IRQ3* (default), *3E8H/IRQ4*, *2E8H/IRQ10*, and *Disabled* for the onboard serial connector.

## IV. BIOS SOFTWARE

---

### Onboard Parallel Port

This field sets the address of the onboard parallel port connector. You can select either: *3BCH/IRQ 7*, *378H/IRQ 7* (default), *278H/IRQ 5*, *Disabled*. If you install an I/O card with a parallel port, ensure that there is no conflict in the address assignments. The PC can support up to three parallel ports as long as there are no conflicts for each port.

### Parallel Port Mode

This field allows you to set the operation mode of the parallel port. The setting *Normal*, allows normal-speed operation but in one direction only; *EPP* allows bidirectional parallel port operation at maximum speed; *ECP* allows the parallel port to operate in bidirectional mode and at a speed faster than the maximum data transfer rate; *ECP+EPP* (default) allows normal speed operation in a two-way mode.

### ECP DMA Select

This selection is available only if you select *ECP* or *ECP+EPP* in the **Parallel Port Mode**. Select either DMA Channel *1, 3* (default), or *Disable*.

### UART2 Use Infrared

When enabled, this field activates the onboard infrared feature and sets the second serial UART to support the infrared module connector on the motherboard. If your system already has a second serial port connected to the onboard COM2 connector, it will no longer work if you enable the infrared feature. By default, this field is set to *Disabled*, which leaves the second serial port UART to support the COM2 serial port connector. See section III of the baseboard manual for the **IrDA-compliant infrared module connector**.

### Onboard PCI IDE Enable

You can select to enable the *primary* IDE channel, *secondary* IDE channel, *both* (default), or *disable* both channels (for systems with only SCSI drives).

### IDE 0 Master/Slave Mode, IDE 1 Master/Slave Mode

Each channel (0 and 1) has both a master and a slave making four IDE devices possible. Because each IDE device may have a different Mode timing (*0, 1, 2, 3, 4*), it is necessary for these to be independent. The default setting of *Auto* will allow auto-detection to ensure the optimal performance.

# IV. BIOS SOFTWARE

## Power Management Setup

This “Power Management Setup” option allows you to reduce power consumption. This feature turns off the video display and shuts down the hard disk after a period of inactivity.

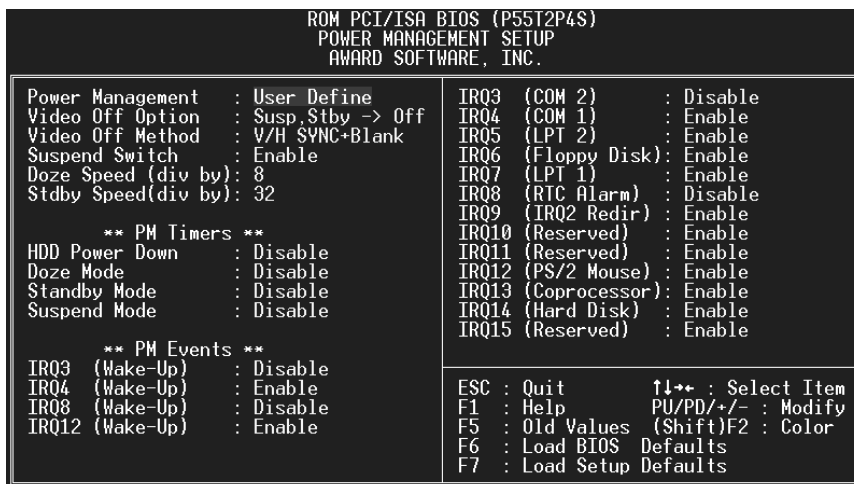

### Details of Power Management Setup:

#### Power Management (User Defined)

This field acts as the master control for the power management modes. There are four options: *Max Saving*, *Min Saving*, *Disabled*, and *User Defined*. *Max Saving* puts the system into power saving mode after a brief period of system inactivity; *Min Saving* is almost the same as *Max Saving* except that this time the system inactivity period is longer; *Disabled* disables the power saving features; *User Defined* allows you to set power saving options according to your preference.

**IMPORTANT:** Advanced Power Management (APM) should be installed to keep the system time updated when the computer enters suspend mode activated by the BIOS Power Management. For DOS environments, you need to add `DEVICE=C:\DOS\POWER.EXE` in you `CONFIG.SYS`. For Windows 3.1x and Windows 95, you need to install Windows including the APM feature. A battery and power cord icon labeled "Power" will appear in the "Control Panel." Choose "Advanced" in the Power Management Field.

#### Video Off Option (Susp, Stby->Off)

This field determines when to activate the video off feature for monitor power management. The settings are *Susp*, *Stby->Off*, *Suspend->Off*, *Always on*, and *All modes->off*.

#### Video Off Method (V/H SYNC + Blank)

This field defines the video off features. Three options are available: *V/H SYNC + Blank*, *DPMS*, and *Blank Only*. The first option, which is the default setting, blanks the screen and turns off vertical and horizontal scanning; *DPMS* (acronym for Display Power Management System) allows the BIOS to control the video display card if it supports the DPMS feature; *Blank Screen* only blanks the screen. Use the latter for monitors that do not support the “Green” (no power management) feature.

Take note that a screen saver software does not work with this feature. While the monitor is shut off, this software cannot display.

# IV. BIOS SOFTWARE

---

## Suspend Switch

This field enables or disables the SMI connector on the motherboard. This connector connects to the lead from the Suspend switch mounted on the system case. Default setting for this field is *Enabled*.

## Doze Speed, Stdby Speed

These two fields set the CPU speed during each mode. The number indicates what the normal CPU speed is divided by.

## PM Timers

This section controls the time-out settings for the Power Management scheme. The fields included in this section are “HDD Power Down”, which places the hard disk into its lowest power consumption mode, and the Doze, Standby and Suspend system inactivation modes.

The system automatically “wakes up” from any power saving mode when there is system activity such as when a key is pressed from the keyboard, or when there is activity detected from the enabled IRQ channels.

**HDD Power Down** shuts down any IDE hard disk drives in the system after a period of inactivity. This time period is user-configurable to *1-15 Mins* or *Disable*. This feature does not affect SCSI hard drives.

The **Doze Mode**, **Standby Mode**, and **Suspend Mode** fields set the period of time after which each of these modes activate. At *Max Saving*, these modes activate sequentially (in the given order) after one minute; at *Min Saving* after one hour.

## PM Events

This section sets the wake-up call of the system. If activity is detected from any enabled IRQ channels in the left-hand group, the system wakes up from suspended mode. You can enable power management for IRQs 3 ~ 15 individually in the list at the right of the screen. The power management feature will work on the enabled IRQ channels.

Take note that a Microsoft serial mouse or compatible will use either COM1 (IRQ4) or COM2 (IRQ3), and a PS/2 mouse will use IRQ12. If you know which IRQ your mouse is using, you can enable the Wake-up Event for that IRQ here and the system will wake up when you move the mouse or click its button.

.....

## Sleep Items (IRQ3-IRQ15)

You can individually *Enable* or *Disable* each IRQ to include in the sleep function. IRQ8 (Real Time Alarm) is usually set to *Disable* so that any software alarm clock or event calendar can wake up the system.

# IV. BIOS SOFTWARE

## PNP and PCI Setup

This “PNP and PCI Setup” option configures the PCI bus slots. All PCI bus slots on the system use INTA#, thus all installed PCI cards must be set to this value.

```
ROM PCI/ISA BIOS (P55T2P4S)
PNP AND PCI SETUP
AWARD SOFTWARE, INC.

Slot 1 (RIGHT) IRQ : Auto
Slot 2 IRQ         : Auto
Slot 3 IRQ         : Auto
Slot 4 (LEFT)  IRQ : Auto
PCI Latency Timer : 32 PCI Clock

IRQ 3 Used By ISA : No/ICU
IRQ 4 Used By ISA : No/ICU
IRQ 5 Used By ISA : No/ICU
IRQ 7 Used By ISA : No/ICU
IRQ 9 Used By ISA : No/ICU
IRQ 10 Used By ISA : No/ICU
IRQ 11 Used By ISA : No/ICU
IRQ 12 Used By ISA : No/ICU
IRQ 14 Used By ISA : No/ICU
IRQ 15 Used By ISA : No/ICU

DMA 1 Used By ISA : No/ICU
DMA 3 Used By ISA : No/ICU
DMA 5 Used By ISA : No/ICU

ISA MEM Block BASE : No/ICU

Onboard AHA BIOS   : Auto
USB Function       : Disabled

ESC : Quit          ↑↓←→ : Select Item
F1  : Help          PU/PD/+/- : Modify
F5  : Old Values   (Shift)F2 : Color
F6  : Load BIOS Defaults
F7  : Load Setup Defaults
```

The first four fields on the screen set how IRQ use is determined for each PCI slot. The default setting for each field is *Auto*, which uses auto-routing to determine IRQ use. The other options are manual settings of *14* or *15* for each slot.

### PCI Latency Timer

The default setting of “32 PCI Clock” enables maximum PCI performance for this motherboard.

### IRQ xx Used By ISA

These fields indicate whether or not the displayed IRQ for each field is being used by a Legacy (non-PnP) ISA card. Two options are available: *No/ICU* and *Yes*. The first option, the default value, indicates either that the displayed IRQ is not used or an ISA Configuration Utility (ICU) is being used to determine if an ISA card is using that IRQ. If you install a Legacy ISA card that requires a unique IRQ, and you are not using an ICU, you must set the field for that IRQ to *Yes*. For example: If you install a Legacy ISA card that requires IRQ 10, then set **IRQ10 Used By ISA** to *Yes*.

### DMA x Used By ISA

These fields indicate whether or not the displayed DMA channel for each field is being used by a Legacy (non-PnP) ISA card. Available options include: *No/ICU* and *Yes*. The first option, the default setting, indicates either that the displayed DMA channel is not used or an ICU is being used to determine if an ISA card is using that channel. If you install a Legacy ISA card that requires a unique DMA channel, and you are not using an ICU, you must set the field for that channel to *Yes*.



## IV. BIOS SOFTWARE

---

### **ISA MEM Block BASE**

This field allows you to set the base address and block size of a Legacy ISA card that uses any memory segment within the C800H and DFFFH address range. If you have such a card, and you are not using an ICU to specify its address range, select a base address from the six available options; the **ISA MEM Block SIZE** field will then appear for selecting the block size. If you have more than one Legacy ISA card in your system that requires to use this address range, you can increase the block size to either 8K, 16K, 36K, or 64K. If you are using an ICU to accomplish this task, leave **ISA MEM Block BASE** to its default setting of *No/ICU*.

### **Onboard AHA BIOS**

The default uses *Auto* settings for the onboard Adaptec 7880 SCSI. If you wish not to use the onboard Adaptec 7880 SCSI, choose *Disabled*

### **USB Function**

This motherboard supports Universal Serial Bus (USB) devices but current operating systems do not. The default is set to *Disabled* until support disks and USB devices are available in which time you can set this function to *Enabled*.

# IV. BIOS SOFTWARE

## Load BIOS Defaults

This “Load BIOS Defaults” option allows you to load the troubleshooting default values permanently stored in the BIOS ROM. These default settings are non-optimal and disable all high performance features. To load these default settings, highlight “Load BIOS Defaults” on the main screen and then press the <Enter> key. The system displays a confirmation message on the screen. Press the <Y> key and then the <Enter> key to confirm. Press the <N> key and then the <Enter> key to abort. This feature does not affect the fields on the Standard CMOS Setup screen.

## Load Setup Defaults

This “Load Setup Defaults” option allows you to load the default values to the system configuration fields. These default values are the optimized configuration settings for the system. To load these default values, highlight “Load Setup Defaults” on the main screen and then press the <Enter> key. The system displays a confirmation message on the screen. Press the <Y> key and then the <Enter> key to confirm. Press the <N> key and then the <Enter> key to abort. This feature does not affect the fields on the Standard CMOS Setup screen.

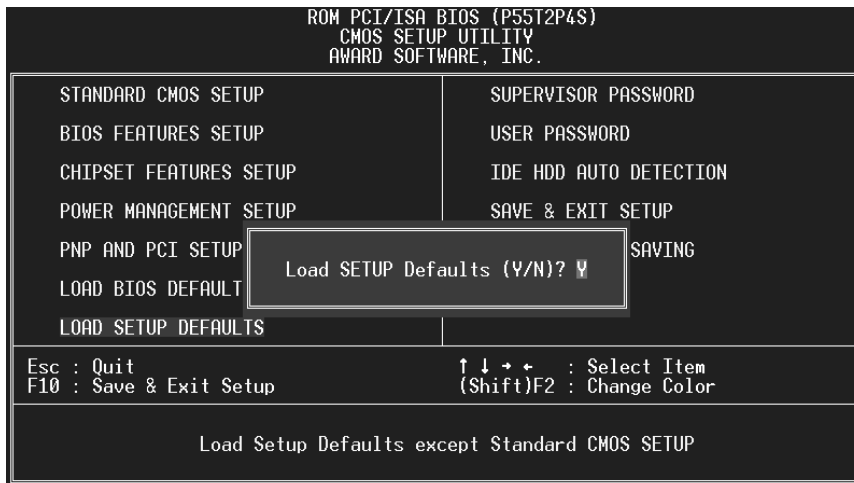

# IV. BIOS SOFTWARE

## Supervisor Password and User Password

These two options set the system passwords. “Supervisor Password” sets a password that will be used to protect the system and the Setup utility; “User Password” sets a password that will be used exclusively on the system. By default, the system comes without any passwords. To specify a password, highlight the type you want and then press the <Enter> key. A password prompt appears on the screen. Taking note that the password is case sensitive, and can be up to 8 alphanumeric characters long, type in your password and then press the <Enter> key. The system confirms your password by asking you to type it again. After setting a password, the screen automatically reverts to the main screen.



To implement the password protection, specify in the “Security Option” field of the BIOS Features Setup screen when the system will prompt for the password. If you want to disable either password, press the <Enter> key instead of entering a new password when the “Enter Password” prompt appears. A message confirms the password has been disabled.

**NOTE:** If you forget the password, see CMOS RAM in section III for procedures on clearing the CMOS.

# IV. BIOS SOFTWARE

## IDE HDD Auto Detection

This “IDE HDD Auto Detection” option detects the parameters of an IDE hard disk drive, and automatically enters them into the Standard CMOS Setup screen.

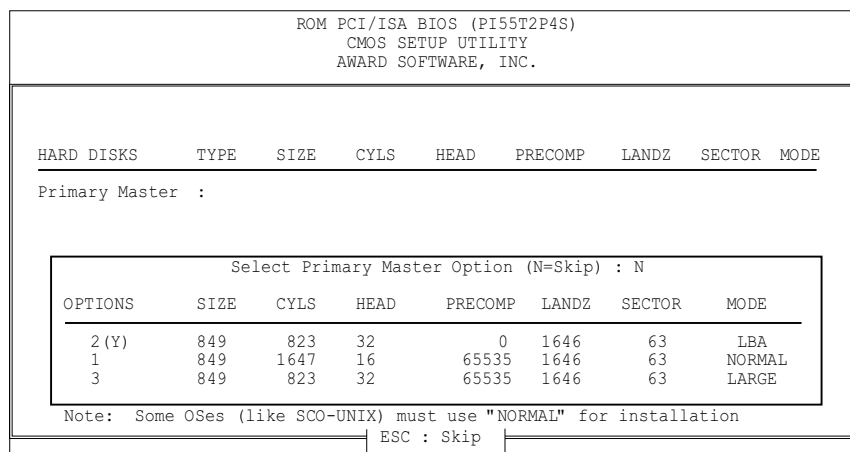

Up to four IDE drives can be detected, with parameters for each listed inside the box. To accept the optimal entries, press the <Y> key or else select from the numbers displayed under the OPTIONS field (2, 1, 3 in this case); to skip to the next drive, press the <N> key. If you accept the values, the parameters will appear listed beside the drive letter on the screen. The process then proceeds to the next drive letter. Pressing the <N> key to skip rather than to accept a set of parameters causes the program to enter zeros after that drive letter.

Remember that if you are using another IDE controller that does not feature Enhanced IDE support for four devices, you can only install two IDE hard disk drives. Your IDE controller must support the Enhanced IDE features in order to use Drive E and Drive F. The onboard PCI IDE controller supports Enhanced IDE, with two connectors for connecting up to four IDE devices. If you want to use another controller that supports four drives, you must disable the onboard IDE controller in the Chipset Features Setup screen.

When auto-detection is completed, the program automatically enters all entries you accepted on the field for that drive in the Standard CMOS Setup screen. Skipped entries are ignored and are not entered in the screen.

If you are auto-detecting a hard disk that supports the LBA mode, three lines will appear in the parameter box. Choose the line that lists LBA for an LBA drive. Do not select Large or Normal.

The auto-detection feature can only detect one set of parameters for a particular IDE hard drive. Some IDE drives can use more than one set. This is not a problem if the drive is new and there is nothing on it.

# IV. BIOS SOFTWARE

**IMPORTANT:** If your hard drive was already formatted on an older previous system, incorrect parameters may be detected. You will need to enter the correct parameters manually or use low-level format if you do not need the data stored on the hard drive.

If the parameters listed differ from the ones used when the drive was formatted, the drive will not be readable. If the auto-detected parameters do not match the ones that should be used for your drive, do not accept them. Press the <N> key to reject the presented settings and enter the correct ones manually from the Standard CMOS Setup screen.

## Save and Exit Setup

Select this option to save into the CMOS memory all modifications you specify during the current session. To save the configuration changes, highlight the “Save & Exit Setup” option on the main screen and then press the <Enter> key.



IV. BIOS  
(Save & Exit)

## Exit Without Saving

Select this option to exit the Setup utility without saving the modifications you specify during the current session. To exit without saving, highlight the “Exit Without Saving” option on the main screen and then press the <Enter> key.

---

(This page was intentionally left blank)

# V. DESKTOP MANAGEMENT

---

## Desktop Management Interface (DMI)

### *Introducing the ASUS DMI Configuration Utility*

This motherboard supports DMI within the BIOS level and provides a DMI Configuration Utility to maintain the Management Information Format Database (MIFD). DMI is able to auto-detect and record information pertinent to a computer's system such as the CPU type, CPU speed, and internal/external frequencies, and memory size. The onboard BIOS will detect as many system information as possible and store those collected information in a 4KB block in the motherboard's Flash EPROM and allow the DMI to retrieve data from this database. Unlike other BIOS software, the BIOS on this motherboard uses the same technology implemented for Plug and Play to allow dynamic real-time updating of DMI information versus creating a new BIOS image file and requiring the user to update the whole BIOS. This DMI Configuration Utility also allows the system integrator or end user to add additional information into the MIFD such as serial numbers, housing configurations, and vendor information. Those information not detected by the motherboard BIOS and has to be manually entered through the DMI Configuration Utility and updated into the MIFD. This DMI Configuration Utility provides the same reliability as PnP updating and will prevent the refreshing failures associated with updating the entire BIOS.

### *System Requirements*

The DMI Configuration Utility (DMICFG.EXE) must be ran in real mode in order for the program to run, the base memory must be at least 180K. Memory managers like HIMEM.SYS (required by windows) must not be installed. You can boot up from a system diskette without AUTOEXEC.BAT and CONFIG.SYS files, "REM" HIMEM.SYS in the CONFIG.SYS, or press <F5> during bootup to bypass your AUTOEXEC.BAT and CONFIG.SYS files.

# V. DESKTOP MANAGEMENT

## Using the ASUS DMI Configuration Utility

### Edit DMI (or delete)

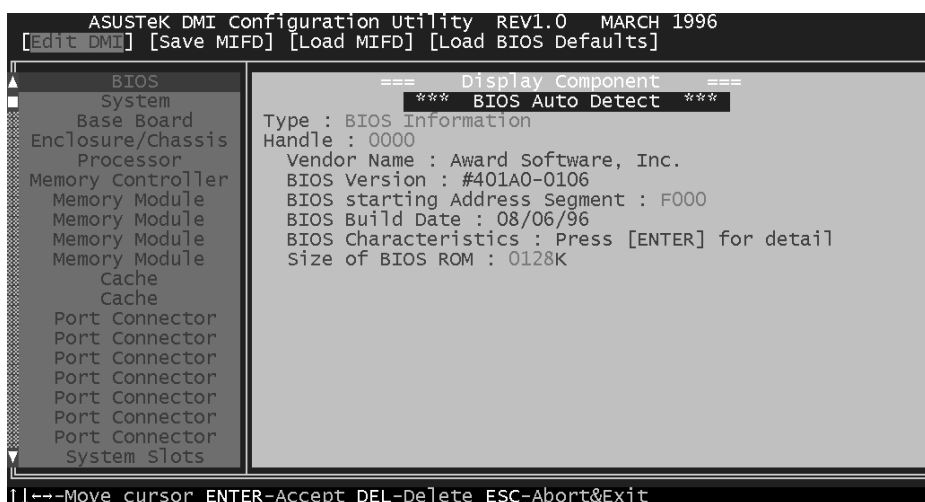

Use the ←→ (left-right) cursors to move the top menu items and the ↑↓ (up-down) cursor to move between the left hand menu items. The bottom of the screen will show the available keys for each screen. Press enter at the menu item to enter the right hand screen for editing. “Edit component” appears on top. The reversed color field is the current cursor position and the blue text are available for editing. The orange text shows auto-detected information and are not available for editing. The blue text “Press [ENTER] for detail” contains a second pop-up menu is available, use the + - (plus-minus) keys to change the settings. Enter to exit *and save*, ESC to exit *and not save*.

If the user has made changes, ESC will prompt you to answer Y or N. Enter Y to go back to the left-hand screen *and save*, enter N to go back to left-hand screen and *not save*. If editing has not been made, ESC will send you back to the left hand menu without any messages.

#### Notes:

A heading, \*\*\* BIOS Auto Detect \*\*\* appears on the right for each menu item on the left side that has been auto detected by the system BIOS.

A heading, \*\*\* User Modified \*\*\* will appear on the right for menu items that has been modified by the user.





# V. DESKTOP MANAGEMENT

---

## Save MIFD



## Load MIFD



## Load BIOS Defaults



---

(This page was intentionally left blank)

# VI. ADAPTEC SCSI SELECT

## Configuring the SCSI Adapter

Access the SCSI BIOS by holding down both **CTRL** and **A** keys when you see the BIOS banner message listing the driver name and the attached devices. For example:

**Adaptec AIC-7880 Ultra/Wide W BIOS v1.24**  
**(c) 1996 Adaptec, Inc. All Rights Reserved.**

**<<< Press <Ctrl><A> for SCSISelect(TM) Utility! >>>**

The SCSISelect screen will come up. Instructions on how to move the cursor and select options are listed on the bottom of the program windows. You can select either **Configure/View Host Adapter Settings** or **SCSI Disk Utilities**.

### *Configure/View Host Adapter Settings*

Host Adapter SCSI Termination.....Low ON/High ON

- When using 50-Pin connector only, choose “Low ON/High ON” (Default)
- When using 68-Pin connector only, choose “Low ON/High ON” (Default)
- **When using both 50-Pin & 68-Pin, choose “Low OFF/High ON”**

Select the default of “Low ON/High ON” and press Enter, then use the up and down arrows to make your new selection and press Enter. Press ESC to go back to the Options menu. Press ESC again and select Yes to exit the program.

### SCSI Disk Utilities

The SCSI Disk Utilities option displays information on SCSI IDs 0 though 15, listing all devices on the bus including non-disk devices. When you select a device from the list and press Enter key, another window appears giving you the option of selecting one of two sub-utilities, **Format Disk** or **Verify Media**. These utilities are used for hard disk drives only and will have no effect on other non-disk SCSI devices.

**Format Disk** - is a SCSI low-level formatting utility. In general, SCSI hard drive have already been low-level formatted when you get them, so you generally should not need to use this function.

**Verify Media** - scans the selected drive media for defects, notifies you of any found and gives you the option of reassigning bad blocks so that data will not be written to them. This is only necessary if you suspect that your SCSI disk drive has a problem.

---

(This page was intentionally left blank)

# VI. ADAPTEC EZ-SCSI UTILITY

---

Welcome to Adaptec EZSCSI<sup>®</sup> 4.00e Adaptec EZSCSI gives you what you need to use your SCSI devices most effectively with Windows<sup>®</sup>95 and WindowsNT<sup>™</sup>. You can also use Adaptec EZSCSI on computers running DOS, Windows<sup>®</sup>3.1x, or Windows for Workgroups3.1x.

## Quick Start Instructions

First, install SCSI devices (see the hardware documentation for details). Then follow the instructions for your operating system software in one of the following sections. We recommend that after you install Adaptec EZSCSI you run SCSTutor to learn more about the features of SCSI.

## Windows95 or WindowsNT

If you want to install Windows95 or WindowsNT on a new computer system, you may not be able to access your SCSI CDROM drive at first. (Usually, you install Windows95 and WindowsNT from a CDROM disc.) To gain access to your CDROM drive, follow the DOS Quick Start instructions on page 4. Then reboot your computer and follow these instructions:

- 1 Install Windows95 or WindowsNT version 3.51 or above, and start it running on your computer.
- 2 Insert the Adaptec EZSCSI Setup Diskette in your floppy disk drive.
- 3 Click the Start button and select Run.
- 4 Type a:\setup if you are using the A drive or b:\setup if you are using the B drive. Then click OK.
- 5 Follow the instructions that appear on the screen.

## Windows/Windows for Workgroups 3.1x

- 1 Install Windows3.1x or Windows for Workgroups3.1x and start it running on your computer.
- 2 Insert the Adaptec EZSCSI Setup Diskette in your floppy disk drive.
- 3 Select File/Run from the Program Manager menu.
- 4 When the Run dialog box appears, type a:\setup if you are using the A drive or b:\setup if you are using the B drive. Then click OK.
- 5 Follow the instructions that appear on the screen.

## DOS

- 1 Install DOS6.x or above and start it running on your computer.
- 2 Insert the Adaptec EZSCSI Setup Diskette in your floppy disk drive.
- 3 At the DOS prompt, type a:\install (assuming your 3.5" floppy is A: drive). Then press Enter.
- 4 Follow the instructions that appear on the screen.

# VI. ADAPTEC EZ-SCSI UTILITY

---

## Troubleshooting Tips

### SCSI Device Troubleshooting

Review this checklist if your newly-installed SCSI disk drives, CDROM drives, and other devices do not seem to work properly:

- Be sure that termination is correctly set for all devices on the SCSI bus, as described in your host adapter documentation.
- Be sure there are no hardware conflicts such as devices in your computer trying to use the same interrupts (IRQs) or DMA channels.
- Be sure the cables connecting the external and internal SCSI devices and the host adapter are attached securely. Also be sure the pin-1 orientation is correct for internal cables. See the host adapter documentation for more information.
- Be sure that each SCSI device connected to the host adapter has a unique SCSI ID.
- Be sure CD-ROM drives and other SCSI devices are attached to a power source and are turned ON.

## Windows95/WindowsNT Troubleshooting

### **What is a miniport driver, and how do I make sure that the miniport driver is installed correctly?**

Miniport drivers are a new kind of 32bit protect mode device driver used by Windows95 and WindowsNT to control host adapters and other kinds of devices. Windows95 and WindowsNT include a set of miniport drivers for various types of SCSI host adapters. The host adapter miniport driver is automatically installed and configured during Windows95 and WindowsNT installation if your host adapter is already installed. To make sure the driver is installed correctly in systems running Windows95, open the Control Panel, double-click on System, and click the Device Manager tab. Then double-click the SCSI Controllers icon; you should see the model name of the SCSI host adapter(s) installed in your system.

### **What if there is no SCSI controllers icon under Device Manager, or the model name of the SCSI chipset does not appear under Device Manager?**

If the SCSI controllers icon or your host adapter's model name do not appear, open Control Panel and double-click the Add New Hardware icon. Let Windows search for the host adapter by selecting Yes on the second screen of the Add New Hardware Wizard.

If Windows does not detect the host adapter, run the Add New Hardware Wizard again. This time, select No on the second screen of the wizard, then select SCSI controllers on the next screen. Select the name of your host adapter when it appears.

## VI. ADAPTEC EZ-SCSI UTILITY

---

**If the name of your SCSI chipset does not appear, you may be able to find its miniport driver on the Windows95 CD-ROM. Follow these steps:**

- 1 Place the Windows95 CD-ROM in your CDROM drive and run the Add New Hardware wizard.
- 2 Select No on the second screen, and select SCSI controllers on the next screen.
- 3 Click on the Have Disk button, then click the Browse button.
- 4 Look in the \drivers\storage directory of the CDROM and select the name of your SCSI host adapter if it appears.

**What if a yellow exclamation point or a red X appears in Device Manager in front of my host adapter?**

This means there is some kind of resource problem. First, see if the names of any host adapters appear that are not actually installed in your computer. If so, select the name and click Remove. If a red X appears in front of your host adapter name, remove all the host adapter references under SCSI Controllers and run Add New Hardware, as described in the previous question/answer. If a yellow exclamation point appears in front of your host adapter name, the resources that the driver uses probably do not match the resources used by the hardware. Double-click the host adapter name, then click on the Resource tab. Deselect the Use automatic settings box and edit the resources (Interrupt Request, Direct Memory Access, etc.) so they match those used by the host adapter. If the problem still remains, there is probably a hardware resource conflict between the host adapter and other hardware in your computer. You can fix this by changing the hardware resource settings. (See your hardware documentation.)

**What do I need to do if I want to use another host adapter?**

- 1 Open the Control Panel, double-click on System, and click the Device Manager tab.
- 2 Double-click the SCSI Controllers icon, select the name of the old host adapter, and click Remove.
- 3 Turn OFF the computer and physically remove the currently installed host adapter.
- 4 Install the new host adapter according to the instructions in the hardware documentation.
- 5 Turn the computer ON. If the new host adapter supports Plug and Play, Windows will install and configure it automatically. Otherwise, run Add New Hardware to make sure the new driver is loaded.

## VI. ADAPTEC EZ-SCSI UTILITY

---

### **If I am running under Windows95, do I need lines for the Adaptec real mode ASPI drivers and mscdex in my config.sys and autoexec.bat files?**

Usually, you do not need to use these real mode ASPI drivers, because the new Windows miniport drivers support most SCSI host adapters and SCSI devices. However, you need to load the drivers (including mscdex, if you have a CDROM drive) if any of the following is true:

- You are running in MSDOS mode
- You are using a scanner or another SCSI device with config.sys- or autoexec.bat-based drivers, such as HP's sjix.sys
- You have an older model SCSI-1 CDROM drive that Windows95 does not support
- You are using a CD-Recorder drive (however, some newer models of CD-Recorder drives can use the embedded Windows miniport drivers)

To install the Adaptec EZSCSI DOS drivers, click the Start button and select **Restart the computer in MS-DOS mode**. When the DOS prompt appears, follow the Quick Start instructions for DOS.

### **My CDROM drive doesn't work properly under Windows95.**

Some older models of SCSI CDROM drives are not compatible with the embedded Windows95 CDROM driver. You can add support for the CDROM drive by doing the following:

- 1 Click the Start button and select Restart the computer in MS-DOS mode.
- 2 When the DOS prompt appears, follow the Quick Start instructions for DOS.
- 3 When you are finished running Adaptec EZSCSI for DOS, find the file named cdttd.vxd in the windows\system\iosubsys directory and rename it cdttd.sav.

### **My CDROM drive shows up as more than one icon under My Computer.**

The mapping between mscdex, which runs in real mode, and the Windows95 CDROM driver does not match. You can correct this in one of two ways:

- Comment out the line that loads mscdex.exe in the autoexec.bat file.
- Change the /L switch on the line that loads mscdex.exe in the autoexec.bat file so it assigns the CDROM drive the next highest logical drive letter after the hard disk drives.



# VI. ADAPTEC EZ-SCSI UTILITY

---

## Information for DOS/Windows 3.1x Users

The following information may be useful if you install Adaptec EZSCSI on a computer running DOS, Windows 3.1x, or Windows for Workgroups 3.1x.

**NOTE: The Windows95/WindowsNT Troubleshooting section on page 6 describes a few situations when you may need to use the DOS/Windows3.1x drivers and ASPI managers under Windows95 or WindowsNT.**

## DOS and Windows3.1x Device Drivers

Device drivers are software programs that enable your computer to communicate with SCSI devices such as hard disk drives, CDROM drives, and scanners. Each kind of device requires a different device driver. Adaptec EZSCSI includes several DOS/Windows3.1x device drivers that are copied to your hard disk during installation. Adaptec EZSCSI adds command lines to your config.sys and autoexec.bat files to load these device drivers if it finds these kinds of devices on your computer.

To learn more about the Adaptec EZSCSI device drivers, including their command line option information, see the online Adaptec EZSCSI Online Reference, a Windows Help application.

## DOS and Windows3.1x ASPI Managers

ASPI (Advanced SCSI Programming Interface) managers are software programs that enable the SCSI device drivers, your host adapter, and your SCSI devices to communicate with each other. ASPI managers are written for a specific operating system, such as DOS, and a specific family of Adaptec host adapters.

Adaptec EZSCSI includes several ASPI managers for DOS/Windows3.1x. When you install Adaptec EZSCSI on these operating systems, it detects what kind of host adapter is installed in your computer and automatically configures your system with the correct ASPI manager. To learn more about these ASPI managers, including their command line option information, see the Adaptec EZSCSI Online Reference, a Windows Help application.

# VI. ADAPTEC EZ-SCSI UTILITY

---

## DOS Formatting Utilities

Adaptec EZSCSI includes several DOS-based formatting utilities:

### *Low-level Formatter (scsifmt)*

Use the DOS-based scsifmt utility for low-level formatting of SCSI hard disk drives, removable media, Floptical<sup>®</sup> drives, and magneto-optical drives. You can also use it to scan a disk device for surface defects before you store data on it.

Run scsifmt from the DOS prompt, not from the Windows MSDOS prompt. Before you run it, be sure the disk devices you want to format are connected to the host adapter and that they are powered. Then follow these steps:

1. Change to the directory where scsifmt.exe is located (usually c:\scsi), type scsifmt at the DOS prompt, and press Enter.

**NOTE: If you are formatting a SCSI disk device that supports more than one LUN (for example, Iomega's Bernoulli dual multdrive) type scsifmt / L at the command line.**

2. When the first screen appears, read it and press Enter to continue. (Press F1 at any time to view Help.) Information about your SCSI disk devices appears on the screen.
3. Use the arrow keys to move the highlight bar to a disk device you want to format or verify, then press Enter.
4. When the next screen appears, select either Format or Verify (to verify that the disk is free of surface defects), then press Enter.

**WARNING:** Back up important data before you format the disk device!  
A low-level format erases all data from the disk.

5. If you select Format, confirm that you want to format the disk, then wait while the disk device is formatted. This may take a long time if the disk is large.  
If you select Verify, you can press Esc at any time to stop the verification process. (This does not damage the disk.) If the utility finds bad blocks on the disk, it displays information about them. You can reassign the bad block(s) to prevent data from being stored there.
6. Repeat steps 3, 4, and 5, as needed, to format or verify other disk devices. When you are finished, press Esc to exit.

# VI. ADAPTEC EZ-SCSI UTILITY

---

## *Formatter and Partitioner (afdisk)*

Use the DOS-based afdisk utility to partition and format SCSI hard disk drives, Floptical drives, and magneto-optical drives. You can also use afdisk to remove DOS and non-DOS partitions from a disk drive and to format removable media in standard hard disk format, OS/2 floppy format, or DOS V (Japanese) format.

**NOTE: Use afdisk only if the disk device is not controlled by the host adapter BIOS—that is, if the host adapter does not have a BIOS or if its BIOS is not enabled. If the disk device is controlled by the host adapter BIOS, use the DOS fdisk utility to partition and format the disk device. (See the MSDOS documentation.)**

Run afdisk from the DOS prompt only, not from the Windows MSDOS prompt. Before you run it, be sure the disk devices you want to format and partition are connected to the host adapter and that they are powered. Then follow these steps:

1. Change to the directory where afdisk.exe is located (usually c:\scsi), type afdisk at the DOS prompt, and press Enter.

Information about your SCSI disk devices appears on the screen. (The number that appears after Target is the device's SCSI ID.)

2. Use the arrow keys to move the highlight bar to the disk device you want to partition, then press Enter.
  - If the selected disk device is controlled by the host adapter BIOS, you can view information about it but you cannot partition it with afdisk (Use the DOS fdisk and format utilities.)
  - If the selected disk device is unpartitioned, you must partition it before you can format it. To do this, follow the instructions on the screen. (Press F1 to see an explanation of the partitioning options.)

Information about the selected disk device appears in the lower left of the screen. Disks smaller than 1Gigabyte have 64 heads, 32 sectors per track, and cylinders equal to the number of MBytes of available capacity. Disks larger than 1Gigabyte have 255 heads, 63sectors per track, and one cylinder per 8MBytes of available capacity.

# VI. ADAPTEC EZ-SCSI UTILITY

- To create a new partition on the disk device, press Ins. A screen similar to this appears:

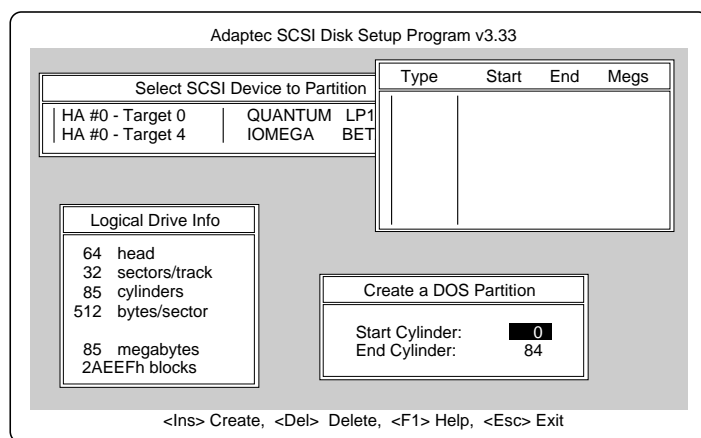

The Create a DOS Partition window suggests that you create one partition on the disk device, equal to its entire capacity. If this is what you want to do, skip to step 5.

- To change the size of the partition, use the arrow keys to select Start Cylinder and End Cylinder, and type in the numbers you want. Partitions up to 2Gigabytes are supported.
- When the number of cylinders is what you want, press Esc. When the confirmation prompt appears, select Yes and press Enter to create the partition. To create more partitions on the same disk device, repeat steps 3, 4, and 5. As you create partitions on the disk, they are added to the window at the upper right of the screen, as shown here:

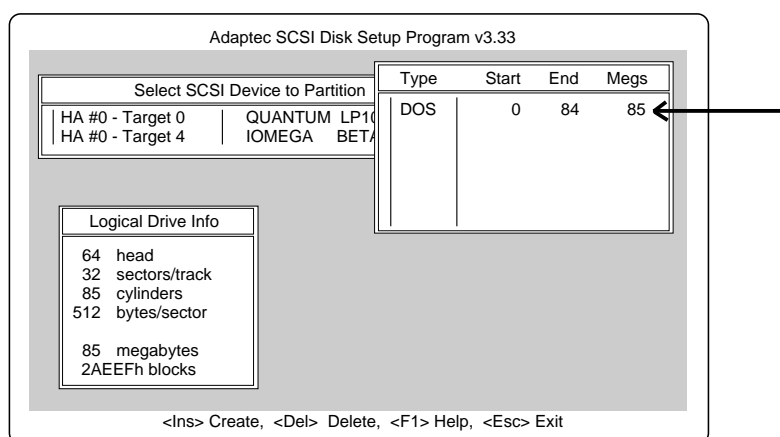

- Press Esc to return to the Select SCSI Device to Partition window. If you want to partition a different disk device, select the device from the list and repeat the earlier steps.
- To quit afdisk, press Esc and select Yes to confirm that you want to quit.