

# **SY-6BA+ IV Motherboard**

## **Quick Start Guide**

Introduction

Hardware  
Installation

Quick BIOS  
Setup

The SOYO CD

The ATA 66  
Driver  
Installation

**FC** Tested To Comply  
With FCC Standards  
FOR HOME OR OFFICE USE

**100%** POST CONSUMER  
RECYCLED PAPER

# SY-6BA+ IV Motherboard

Pentium® III, Pentium® II & Celeron™ processors  
82440 BX AGP/PCI Motherboard  
66&100MHz Front Side Bus supported  
ATX Form Factor

Copyright © 1999 by Soyo Computer Inc.

## **Trademarks:**

Soyo is a registered trademark of Soyo Computer Inc. All trademarks are the property of their owners.

## **Product Rights:**

Product and corporate names mentioned in this publication are used for identification purposes only and may be registered trademarks or copyrights of their respective companies.

## **Copyright Notice:**

All rights reserved. This manual is copyrighted by Soyo Computer Inc. You may not reproduce, transmit, transcribe, store in a retrieval system, or translate into any language, in any form or by any means, electronic, mechanical, magnetic, optical, chemical, manual or otherwise, any part of this publication without express written permission of Soyo Computer Inc.

## **Disclaimer:**

Soyo Computer Inc. makes no representations or warranties regarding the contents of this manual. We reserve the right to revise the manual or make changes in the specifications of the product described within it at any time without notice and without obligation to notify any person of such revision or change. The information contained in this manual is provided for general use by our customers. Our customers should be aware that the personal computer field is the subject of many patents. Our customers should ensure that their use of our products does not infringe upon any patents. It is the policy of Soyo Computer Inc. to respect the valid patent rights of third parties and not to infringe upon or assist others to infringe upon such rights.

## **Restricted Rights Legend:**

Use, duplication, or disclosure by the Government is subject to restrictions set forth in subparagraph (c)(1)(ii) of the Rights in Technical Data and Computer Software clause at 252.277-7013.

## **About This Guide:**

This Quick Start Guide is for assisting system manufacturers and end users in setting up and installing the Motherboard. Information in this guide has been carefully checked for reliability; however, no guarantee is given as to the correctness of the contents. The information in this document is subject to change without notice.

If you need any further information, please visit our **Web Site** on the Internet. The address is "<http://www.soyo.com.tw>".

**6BA+ IV Serial - Version 1.1 - Edition: December 1999**

\* These specifications are subject to change without notice

# 1 Introduction

Congratulations on your purchase of the **SY-6BA+ IV** Motherboard. This *Quick Start Guide* describes the steps for installing and setting up your new Motherboard.

This guide is designed for all users to provide the basic steps of Motherboard setting and operation. For further information, please refer to *SY-6BA+ IV Motherboard User's Guide and Technical Reference* online manual included on the CD-ROM packed with your Motherboard.

## Unpacking

When unpacking the Motherboard, check for the following items:

- ◆ The SY-6BA+ IV 82440 BX AGP/PCI Motherboard

- ◆ The Quick Start Guide

- ◆ The Installation CD-ROM

- ◆ SOYO 3-in-1 Bonus Pack CD-ROM (Norton AntiVirus, Ghost and Virtual Drive)

- ◆ The CPU Retention Set

- ◆ One IDE Device ATA 66 Flat Cable

- ◆ One IDE Device Flat Cable

- ◆ One Floppy Disk Drive Flat Cable

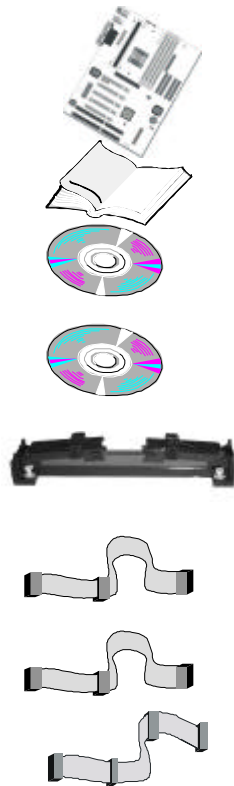

# SY-6BA+ IV Quick Start Guide

## SY-6BA+ IV Motherboard Layout

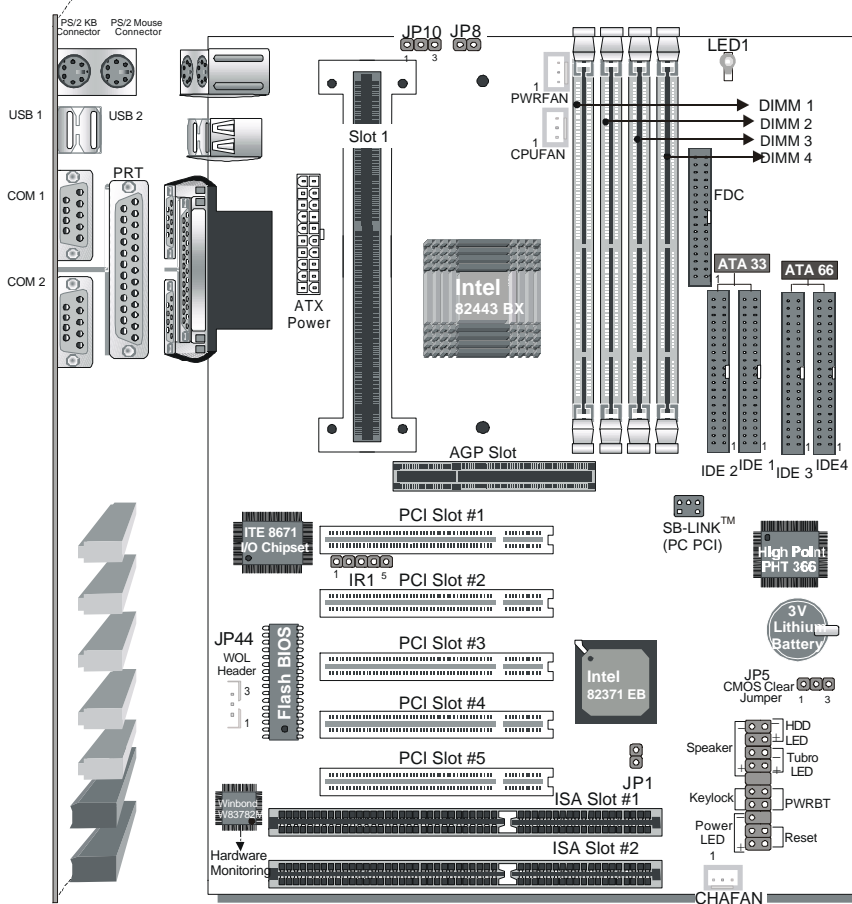

### Key Features

- Supports Intel Pentium® III processor (450-600MHz), Pentium® II processor (233-450MHz) & Celeron™ processor (266-433MHz)
- Jumperless and CPU voltage Adjustable
- PC98, ACPI
- Supports ATA 66/33 (Ultra DMA 66/33)
- Power-on by modem or alarm
- SOYO COMBO Setup
- Supports Wake-On-LAN (WOL)
- Supports onboard hardware monitoring and includes Hardware Doctor™ utility
- Supports Creative SB-LINK™ for PCI audio card
- 1 x 32-bit AGP slot
- 5 x 32-bit bus master PCI slots
- 2 x USB ports onboard
- 1 x IrDA port
- Supports multiple-boot function
- Y2K Compliant
- Supports Power Failure Resume

## 2 Installation



To avoid damage to your Motherboard, follow these simple rules while handling this equipment:

- Before handling the Motherboard, ground yourself by grasping an unpainted portion of the system's metal chassis.
- Remove the Motherboard from its anti-static packaging. Hold it by the edges and avoid touching its components.
- Check the Motherboard for damage. If any chip appears loose, press carefully to seat it firmly in its socket.

Follow the directions in this section designed to guide you through a quick and correct installation of your new **SY-6BA+ IV** Motherboard. For detailed information, please refer to *SY-6BA+ IV Motherboard User's guide and Technical Reference* online manual included on the CD-ROM packed with your Motherboard.

### PREPARATIONS

Gather and prepare all the necessary hardware equipment to complete the installation successfully:

- ◆ Slot 1 processor with built-in CPU cooling fan (boxed type)
- ◆ SDRAM module
- ◆ Computer case and chassis with adequate power supply unit
- ◆ Monitor
- ◆ PS/2 Keyboard
- ◆ Pointing Device (PS/2 mouse)
- ◆ VGA Card
- ◆ Sound Card (optional)
- ◆ Speaker(s) (optional)
- ◆ Disk Drives: HDD, CD-ROM, Floppy drive ...
- ◆ External Peripherals: Printer, Plotter, and Modem- (optional)
- ◆ Internal Peripherals: Modem and LAN cards (optional)

## SY-6BA+ IV Quick Start Guide

### Install the Motherboard

Follow the steps below in order to perform the installation of your new **SY-6BA+ IV** Motherboard.

#### Step 1. Install the CPU

**Mark your CPU Frequency:** Record the working frequency of your CPU that should be clearly marked on the CPU cover.





##### FSB 66MHz

<input type="checkbox"/> 266MHz (66 x 4.0)	<input type="checkbox"/> 333MHz (66 x 5.0)	<input type="checkbox"/> 400MHz (66 x 6.0)	<input type="checkbox"/>
<input type="checkbox"/> 300MHz (66 x 4.5)	<input type="checkbox"/> 366MHz (66 x 5.5)	<input type="checkbox"/> 433MHz (66 x 6.5)	

##### FSB 100MHz

<input type="checkbox"/> 350MHz (100 x 3.5)	<input type="checkbox"/> 450MHz (100 x 4.5)	<input type="checkbox"/> 550MHz (100 x 5.5)	<input type="checkbox"/>
<input type="checkbox"/> 400MHz (100 x 4.0)	<input type="checkbox"/> 500MHz (100 x 5.0)	<input type="checkbox"/> 600MHz (100 x 6.0)	

**CPU Mount Procedure:** To mount the processor that you have purchased separately, follow these instructions.

Retention Module	Step 1. Open the two sides by folding them up.
	
<b>Step 2.</b> Insert the CPU into the retention module. The CPU fits in the CPU slot in only ONE way, do not try to force it in.	<b>Step 3.</b> After completely inserting the CPU, Now your CPU is ready for use.
	

**Note:** Installing a heat sink and cooling fan on top of your CPU is necessary for proper heat dissipation. Failing to install these items may result in overheating and possible burn-out of your CPU.

**Step 2. Make Connections to the Motherboard**

This section tells how to connect internal peripherals and power supply to the Motherboard.

Internal peripherals include IDE devices (HDD, CD-ROM), Floppy Disk Drive, Chassis Fan, Front Panel Devices (Turbo LED, Internal Speaker, Reset Button, IDE LED, and KeyLock Switch.), Wake-On-LAN card, VGA card, Sound Card, and other devices.

For more details on how to connect internal and external peripherals to your new SY-6BA+ IV Motherboard, please refer to *SY-6BA+ IV Motherboard User's Guide and Technical Reference* online manual on CD-ROM.

**Connectors and Plug-ins**

<b>PCI Audio Card Header: SB-Link™(PC-PCI)</b>				<b>Wake-On-LAN Header: JP44</b>						
Connect the SB-Link™(PC-PCI) cable from your PCI audio card to this header.				Pin1	Pin2	Pin3				
				5VSB	GND	MP-Wakeup				
<b>CPU Cooling Fan: CPUFAN</b>			<b>Power Fan: PWRFAN</b>			<b>Chassis Fan: CHAFAN</b>				
Pin1	Pin2	Pin3	Pin1	Pin2	Pin3	Pin1	Pin2	Pin3		
GND	12V	SENSOR	GND	12V	SENSOR	GND	12V	SENSOR		
						<b>Power LED</b>		<b>Keylock</b>		
						Pin1	Pin2	Pin3	Pin1	Pin2
						5V	NC	GND	Control Pin	GND
						<b>Speaker</b>				
						Pin1	Pin2	Pin3	Pin4	
						5V	NC	NC	Speaker out	
<b>HDD LED</b>		<b>Turbo LED</b>		<b>PWRBT</b>		<b>RESET</b>				
Pin1	Pin2	Pin1	Pin2	Pin1	Pin2	Pin1	Pin2			
LED Anode	LED Cathode	LED Cathode	GND	Power On/Off	GND	Power Good	GND			
<b>IrDA (Infrared Device Header): IR1</b>										
Pin1		Pin2		Pin3		Pin4		Pin5		
VCC		None		IRRX		GND		IRTX		
<b>ATX Power On/Off: PWRBT</b>				<b>ATX Power Supply: ATX PW</b>						
Connect your power switch to this header (momentary switch type).				Attach the ATX Power cable to this connector. (This motherboard requires an ATX power supply, an AT power supply can NOT be used.)						
<b>To turn off the system, please press this switch and hold down for longer than 4 seconds.</b>				<b>Note: Please make sure the ATX power supply is able to provide at least 720mA of current on the +5VSB lead if you want to enable the advanced power management functions, like power failure resume, Power-On by keyboard, etc.</b>						

Hardware Installation

## SY-6BA+ IV Quick Start Guide

### Step 3. Configure Memory

Your board comes with four DIMM sockets, providing support for up to 1GB of main memory using DIMM modules from 8MB to 256MB. For 66MHz front side bus CPUs use 12ns or faster memory; for 100MHz front side bus CPUs use 8ns (100MHz, PC100 compliant) memory.

### Memory Configuration Table

Number of Memory Modules	DIMM 1	DIMM 2	DIMM 3	DIMM 4
1	1 <sup>st</sup>			
2	1 <sup>st</sup>	2 <sup>nd</sup>		
3	1 <sup>st</sup>	2 <sup>nd</sup>	3 <sup>rd</sup>	
4	1 <sup>st</sup>	2 <sup>nd</sup>	3 <sup>rd</sup>	4 <sup>th</sup>
RAM Type	SDRAM			
Memory Module Size (MB)	8/16/32/64/128/256 Mbytes			
<b>Note:</b> (1) 256 MB memory modules only available on PC registered DIMM. (2) Always install memory modules in the order prescribed in this table. (3) Do not install unbuffered and registered memory modules together.				

**Important:** It is of prime importance that you install DIMM modules as outlined in the table above in order to preserve signal integrity on 100MHz front side bus systems.

### Step 4. CPU multiplier release Jumper: (JP8)



Closing JP8 can make higher multiplier settings available on some INTEL CPUs. For technical details read the following:

Your Pentium CPU has an input pin B21 (100/66# signal) to tell it at what Front Side Bus (FSB) Frequency it is running; JP8 is connected to this input pin. The actual FSB Frequency is however set through the BIOS and it may therefore differ from the Frequency specified to the CPU through JP8.

Because some INTEL CPUs have their multipliers limited at a FSB Frequency of 100MHz and higher, telling the CPU that it is running at 66MHz though JP8 while setting a different (higher) FSB Frequency in the BIOS may allow the user to set a higher multiplier value. Doing so will however force your CPU to operate out of its specifications, and therefore SOYO can not guarantee the proper functioning of your system.



Refer to the following table:

Mode	JP8
<b>66MHz FSB clock CPUs Setting</b>	
66MHz FSB clock CPUs must use this setting	 <span style="margin-left: 20px;">short</span>
<b>100MHz FSB clock CPUs Setting</b>	
Normal	 <span style="margin-left: 20px;">open</span>
Possible higher multiplier limit	 <span style="margin-left: 20px;">short</span>
<i>Note: Shorting the jumper will tell the CPU that it is running on 66MHz, this will release more multiplier settings on some INTEL CPUs, but will make the system operate out of its specifications if the actual frequency is 100 MHz or higher.</i>	

### Step 5. Set the CPU Frequency

You do not need to set any jumper for the CPU frequency. Instead, CPU settings are changed through the BIOS **[SOYO COMBO SETUP]**. Please refer to *Chapter 3 - Quick BIOS Setup* for details on how to set the Slot 1 processor frequency.

### Step 6. External Suspend Button (JP1)

Some cases come with a suspend button, insert the plug into JP1. In addition to this button, the system can also enter the suspend mode through your OS.



*Note: Suspend mode only functions if your Power Management mode is APM. Make sure that the BIOS setting for Power Management is APM. Windows 98 can be installed with ACPI Power Management (default is APM), in this case suspend mode will not function either.*



### Step 7. 5V Stand-by indicator LED (LED 1)

This LED is lit whenever the 5V Standby voltage coming from the ATX powersupply is available. If you have connected your ATX powersupply to the mains, LED 1 should be lit.

## SY-6BA+ IV Quick Start Guide



### Step 8. Enable/Disable Power-On by Keyboard (JP10)

You can choose to enable the Power-On by Keyboard function by shorting pin 1-2 on jumper JP10, otherwise, short pin 2-3 to disable this function.

Power-On by Keyboard	Enable	Disable
<b>JP10 Setting</b>	Short pin 1-2 to enable the Power-On by Keyboard function. 	Short pin 2-3 to disable the Power-On by Keyboard function. 
<b>Important:</b> When using the Power-On by Keyboard function, please make sure the ATX power supply can take at least 720mA load on the 5V Standby lead (5VSB) to meet the standard ATX specification.		

### Step 9. Clear CMOS Data (JP5)

Clear the CMOS memory by momentarily shorting pin 2-3 on jumper JP5 for at least 5 seconds, and then by shorting pin 1-2 to retain new settings. This jumper can be easily identified by its white colored cap.

CMOS Clearing	Clear CMOS Data	Retain CMOS Data
<b>JP5 Setting</b>	Short pin 2-3 for <b>at least 5 seconds</b> to clear the CMOS. 	Short pin 1-2 to retain the new settings. 
<b>Note:</b> You must unplug the ATX power cable from the ATX power connector when performing the CMOS Clear operation.		

### IDE Connectors



The 6BA+ IV comes with four IDE connectors, with support for up to 8 IDE Devices. For the supported interface modes, refer to the table below:

IDE Connector	PIO mode	DMA Mode	ULTRA DMA33 (ATA 33)	ULTRA DMA66 (ATA 66)
IDE 1 & 2	Yes	Yes	Yes	No
IDE 3 & 4	Yes	Yes	Yes	Yes

**Note:** It is required to connect the ATA66 HDDs with the ATA66 flat cable to the motherboard to maintain proper functionality and stability of the ATA66 high speed interface.

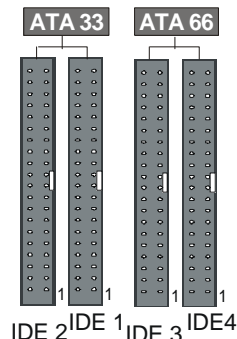



### *Note on Over-clocking Capability*

The SY-6BA+ IV provides over-clocking capability. Due to the over-clocking setting your system may fail to boot up or hang during run time. Please perform the following steps to recover your system from the abnormal situation :

1. Turn off system power (If you use an ATX power supply, and depending on your system, you may have to press the power button for more than 4 seconds to shut down the system.)
2. Set the JP8 to short if you use a FSB 66MHz CPU
3. Press and hold down the <Insert> key while turning on the system power. Keep holding down the <Insert> key until you see the message of the CPU type and frequency shown on the screen.
4. Press the <Del> key during the system diagnostic checks to enter the Award BIOS Setup program.
5. Select [SOYO COMBO SETUP] and move the cursor to the [CPU Frequency] field to set the proper working frequency.
6. Select [Save & Exit SETUP] and press <Enter> to save the new configuration to the CMOS memory, and continue the boot sequence.

**Note: SOYO does not guarantee system stability if the user over clocks the system. Any malfunctions due to over-clocking are not covered by the warranty.**

# 3 Quick BIOS Setup

This Motherboard does not use any hardware jumpers to set the CPU frequency. Instead, CPU settings are software configurable with the BIOS **[SOYO COMBO SETUP]**. The [SOYO COMBO SETUP] menu combines the main parameters that you need to configure, all in one menu, for a quick setup in BIOS.

After the hardware installation is complete, turn the power switch on, then press the **<DEL>** key during the system diagnostic checks to enter the Award BIOS Setup program. The CMOS SETUP UTILITY will display on screen. Then, follow these steps to configure the CPU settings.

**Step 1.** Select [STANDARD CMOS SETUP]

Set [Date/Time] and [Floppy drive type], then set [Hard Disk Type] to "Auto".

**Step 2.** Select [LOAD SETUP DEFAULT]

Select the "LOAD SETUP DEFAULT" menu and type "Y" at the prompt to load the BIOS optimal setup.

**Step 3.** Select [SOYO COMBO SETUP]

Move the cursor to the **[CPU Frequency]** field to set the CPU frequency.

Available [CPU Frequency] settings on your SY-6BA+ IV Motherboard are detailed in the following table.

CPU Frequency (MHz)		Select the working frequency of your Pentium®III, Pentium®II, Celeron™ processor among these preset values.  <b>Note:</b> <input checked="" type="checkbox"/> Mark the checkbox that corresponds to the working frequency of your Pentium®III Pentium® III , Celeron™ processor in case the CMOS configuration should be lost.
<input type="checkbox"/> Manual	<input type="checkbox"/> 350MHz (100 x 3.5)	
<input type="checkbox"/> 233MHz (66 x 3.5)	<input type="checkbox"/> 400MHz (100 x 4 )	
<input type="checkbox"/> 266MHz (66 x 4 )	<input type="checkbox"/> 450MHz (100 x 4.5)	
<input type="checkbox"/> 300MHz (66 x 4.5)	<input type="checkbox"/> 500MHz (100 x 5 )	
<input type="checkbox"/> 333MHz (66 x 5 )	<input type="checkbox"/> 550MHz (100 x 5.5)	
<input type="checkbox"/> 366MHz (66 x 5.5)	<input type="checkbox"/> 600MHz (100 x 6 )	
<input type="checkbox"/> 400MHz (66 x 6 )	<input type="checkbox"/> 650MHz (100 x 6.5)	
<input type="checkbox"/> 433MHz (66 x 6.5)	<input type="checkbox"/> 700MHz (100 x 7 )	
<input type="checkbox"/> 466MHz (66 x 7 )	<input type="checkbox"/>	

If you set this field to [Manual], you are then required to fill in the next two consecutive fields: (1) the CPU Host/PCI Clock, and (2) the CPU Ratio.

**(1) CPU Host/PCI Clock**

CPU Host / PCI Clock					Under this item you find the frequencies your PCI and AGP slots run at. These frequencies are derived from the CPU host clock in the following way: CPU host clock > 100MHz PCI = CPU host clock /3, CPU host clock < 100MHz PCI = CPU host clock /2,
<input type="checkbox"/> 66/33	<input type="checkbox"/> 95/31	<input type="checkbox"/> 115/38	<input type="checkbox"/> 124/41	<input type="checkbox"/> 140/35	
<input type="checkbox"/> 75/37	<input type="checkbox"/> 100/33	<input type="checkbox"/> 117/39	<input type="checkbox"/> 126/31	<input type="checkbox"/> 142/35	
<input type="checkbox"/> 78/39	<input type="checkbox"/> 105/35	<input type="checkbox"/> 118/39	<input type="checkbox"/> 133/33	<input type="checkbox"/> 144/36	
<input type="checkbox"/> 81/40	<input type="checkbox"/> 110/36	<input type="checkbox"/> 120/40	<input type="checkbox"/> 135/33	<input type="checkbox"/> 150/37	
<input type="checkbox"/> 83/40	<input type="checkbox"/> 112/37	<input type="checkbox"/> 122/37	<input type="checkbox"/> 137/34	<input type="checkbox"/> 155/38	
<input type="checkbox"/> 90/30	<input type="checkbox"/> 113/37	<input type="checkbox"/> 124/31	<input type="checkbox"/> 138/34		

**(2) CPU Ratio**

After you have selected the CPU Host/ PCI Clock, choose the right multiplier for the CPU. CPU Ratio options are:

<input type="checkbox"/> x 2	<input type="checkbox"/> x 2.5	<input type="checkbox"/> x 3	<input type="checkbox"/> x 3.5	<input type="checkbox"/> x 4
<input type="checkbox"/> x 4.5	<input type="checkbox"/> x 5	<input type="checkbox"/> x 5.5	<input type="checkbox"/> x 6	<input type="checkbox"/> x 6.5
<input type="checkbox"/> x 7	<input type="checkbox"/> x 7.5	<input type="checkbox"/> x 8		

The CPU frequency is then defined as [host clock freq.] x [multiplier], and should be the working frequency of your CPUs processor.

**(3) AGP Clock**

This option allows you to manually adjust the AGP host bus clock frequency to a value determined as a fraction of the CPU host clock.

For example:

With a CPU front side bus of 100MHz,

[Auto] sets → When [auto] is selected and the (FSB Frequency) is less than 100MHz, it will be divided by [ / 1]. Otherwise it will be divided by [ / 1.5].

[ / 1] sets → AGP Clock = 100MHz

[ / 1.5] sets → AGP Clock = 66.6MHz

AGP Clock options are:

<input type="checkbox"/> Auto	<input type="checkbox"/> ÷1.0	<input type="checkbox"/> ÷1.5
-------------------------------	-------------------------------	-------------------------------

## SY-6BA+ IV Quick Start Guide

---

### (4) Vcore Voltage Adjust

The CPU notifies the board of what core voltage it requires by its VID outputs. The on-board voltage regulator uses the VID code to set the core voltage. If the **Vcore Voltage Adjust** is set to normal, the Vcore will be exactly what the VID code specifies. If an adjustment percentage is selected the Vcore will be that percentage higher than the VID code specifies. For instance the CPU VID code specifies 2.0V and the Vcore Voltage adjust is set to +10.0% the actual CPU Voltage will be 2.2V. This function should only be used if the CPU is running on FSB Frequencies beyond the CPU specifications, note that SOYO does not guarantee system stability if this item is not set to normal.

<input type="checkbox"/> Normal	<input type="checkbox"/> + 2.5 %	<input type="checkbox"/> + 5.0 %	<input type="checkbox"/> + 7.5%	<input type="checkbox"/> +10.0 %
---------------------------------	----------------------------------	----------------------------------	---------------------------------	----------------------------------

### **Step 4.** Select [SAVE & EXIT SETUP]

Press <Enter> to save the new configuration to the CMOS memory, and continue the boot sequence.

## 4 The SOYO CD



**The SOYO-CD will NOT autorun if you use it on an Operating System other than Windows 9x or NT.**

Your SY-6BA+ IV Motherboard comes with a CD-ROM labeled "SOYO CD." The SOYO CD contains (1) the user's manual file for your new Motherboard, (2) the drivers software available for installation, and (3) a database in HTML format with information on SOYO Motherboards and other products.

**Step 1.** Insert the SOYO CD into the CD-ROM drive  
The SOYO CD will auto-run, and the SOYO CD Start Up Menu will be as shown.

If you use Windows NT, the SOYO-CD will not detect your motherboard type. In that case the following dialog will pop up, please choose your motherboard and press OK. Now the SOYO-CD Start Up Menu will be shown.

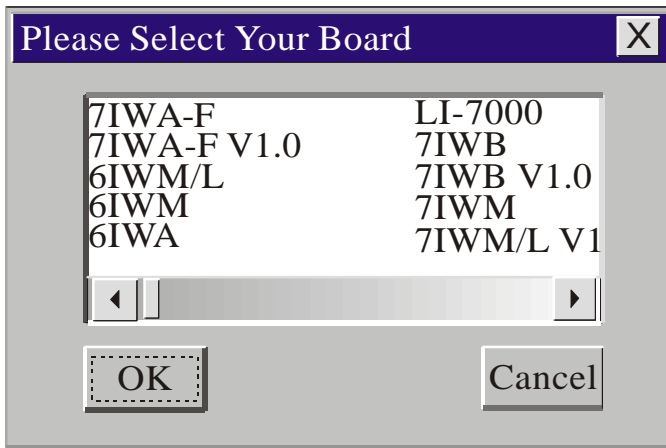

**(SOYO CD Start Up Program Menu)**

If you use Windows 95 or 98, the SOYO CD Start Up Program automatically detects which SOYO Motherboard you own and displays the corresponding model name.

## SY-6BA+ IV Quick Start Guide



The user's manual files included on the SOYO CD are in PDF (Postscript Document) format. In order to read a PDF file, the appropriate Acrobat Reader software must be installed in your system.

**Note:** The Start Up program automatically detects if the Acrobat Reader utility is already present in your system, and otherwise prompts you on whether or not you want to install it. You must install the Acrobat Reader utility to be able to read the user's manual file. Follow the instructions on your screen during installation, then once the installation is completed, restart your system and re-run the SOYO CD.

### **Step 2.** Install Drivers & Utility

Click the **Install Drivers** button to display the list of drivers software that can be installed with your Motherboard. The Start Up program displays the drivers available for the particular model of Motherboard you own. We recommend that you only install those drivers.

However, to display the list of all drivers software available with SOYO Motherboards, click the **Display all drivers on the SOYO CD** button. Please make sure to install only the drivers adapted to your system, or otherwise this may cause system malfunctions.



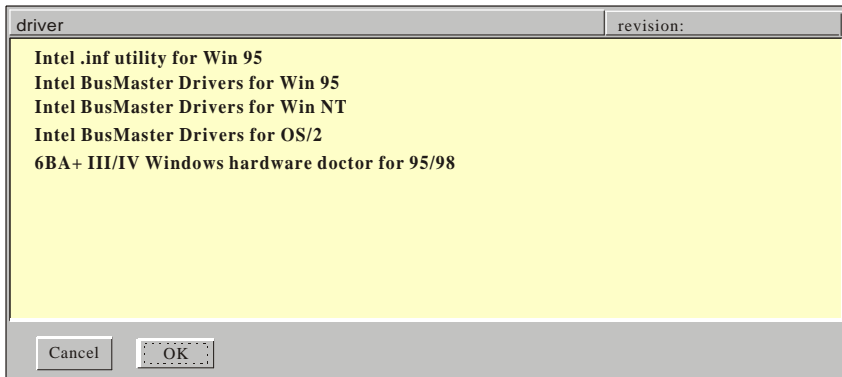

(Driver Installation Menu)

### A short description of all available drivers follows:

#### ➤ Intel .inf utility for Win 95

Because Windows 95 does not recognize the Southbridge of the newer Intel chipsets (TX, BX, ZX etc) this utility has to be run, it will update the necessary Windows .inf files. (Only for Windows 95)

#### ➤ Intel Busmaster Drivers for Windows 95

#### ➤ Intel Busmaster Drivers for Win NT

#### ➤ Intel Busmaster Drivers for OS/2

These are the official busmaster drivers as supplied by Intel.



**Note:** Do NEVER install two types of busmaster drivers on your system, this will lead to conflicts and system instability.

#### ➤ 6BA+ III/IV Windows hardware doctor for 95/98

Your motherboard comes with a hardware monitoring IC. By installing this utility Temperature, Fan speed and Voltages can be monitored. It is also possible to set alarms when current system values exceed or fall below pre-set values.

This utility comes with a preset monitoring range for the CPU voltage. However, the core voltage of the processor you purchased may fall out of this preset range, so you may need to adjust the pre-set value. Please refer to the SY-6BA+ IV Motherboard's CD manual for the details.

Select which driver you want to install and click **OK**, or click **Cancel** to abort the driver installation and return to the main menu.

## SY-6BA+ IV Quick Start Guide

---

**Note:** Once you have selected a driver, the system will automatically exit the SOYO CD to begin the driver installation program. When the installation is complete, most drivers require to restart your system before they can become active.

### Step 3. Check the Latest Releases

Click the 'Check the latest Releases' button to go the SOYO Website to automatically find the latest BIOS, manual and driver releases for your motherboard. This button will only work if your computer is connected to the internet through a network or modem connection. Make sure to get your modem connection up before clicking this button.

### Step 4. Enter the SOYO CD

Click the **Enter SOYO CD** button to enter the SOYO HTML database. The Start Up program will activate the default HTML browser installed on your system (for example, Internet Explorer or Netscape) to display the contents of the SOYO CD.

The SOYO CD contains useful information about your Motherboard and other SOYO products available. For your convenience, this information is available in HTML format, similar to the format widely used on the Internet.



**Note:** If no HTML browser is installed on your system, the Start Up program will prompt you on whether or not you would like to install the Internet Explorer\* browser. Click YES to install the HTML browser. After the installation is complete, please restart your system. Then re-run the SOYO CD and you will be able to browse the SOYO HTML database.

(\* Internet Explorer is a Microsoft Trademark)

## 5 The ATA 66 Driver Installation

### Installing the Windows 95/98 Drivers

Usually, when you boot up the Windows 95/98 system for the first time, the system will be able to detect the HPT366 Ultra DMA host Adapter automatically and ask you to install the driver for HPT366. You can just follow the instructions prompted by the system to install the driver. The driver is located in the following directory:

*D:\drivers\hp-ata66\Win9X* (Where D is your CD-ROM driver letter)

Otherwise, you can install the driver by the following steps:

1. Windows 95/98 must be installed on the system prior to installing the driver.
2. Close any running applications.
3. Open "My Computer".
4. Double click on the "Control Panel" icon.
5. Double click on the "Add New Hardware" applet.
6. Click on the "Next" button.
7. When asked "Do you want Windows to search for your new hardware?", choose "No" then click on the "Next" button.
8. When asked to select the hardware type, select the "SCSI controllers" and click on the "Next" button.
9. Make sure that the SOYO-CD is in your CD-ROM drive and click on the "Have Disk..." button.
10. Select the *D:\drivers\hp-ata66\Win9X* directory (Where D is your CD-ROM driver letter) and click on the "OK" button.
11. Click on the "Next" button.
12. If there is a window showing the settings (resources) to be used by the driver, then click on the "Next" again. At this point, the system will install the driver.
13. Click on the "Finish" button.
14. Then the system will ask you to restart the system. If the settings reported in step 12 are not what set on the host adapter, you must adjust the settings by using the device manager in the System control panel before restarting your computer.
15. The driver for ACPI function is useful only if hardware supports ACPI function.

### Uninstalling the Driver

You can use the device manager in the System control panel to remove the driver.

### Installing the Windows NT 4.0 Drivers

## SY-6BA+ IV Quick Start Guide

---

When Windows NT is up, install the HPT366 device driver as follows:

1. Installing Device Driver
  - (1.) Open My Computer
  - (2.) Open Control Panel
  - (3.) Double click icon SCSI Adapters
  - (4.) Click Drivers
  - (5.) Click Add...
  - (6.) Click Have Disk...
  - (7.) Insert the SOYO-CD with the HPT366 Windows NT 4.0 device driver into your CD-ROM drive, and type "D:\drivers\hpa-ta66\NT40[Enter]", then click OK. (for D type your CD-ROM driver letter)
  - (8.) Select HPT366 Ultra DMA Controller, you will be asked to enter the full path to the HPT366 Ultra DMA Controller files, type in D:\drivers\hpa-ta66\NT40 and then click Continue
  - (9.) When asked to restart your computer, click Yes

Your hard disk drive attached to the HPT366 host adapter must be partitioned and formatted before you can access it. Please see Partitioning Your Hard Disk to know how to partition and format a hard disk drive.

### 2. Checking the Installation

If you want to check if the HPT366 host adapter and its device driver are correctly installed, you can:

- (1.) Open My Computer
- (2.) Open Control Panel
- (3.) Double click icon SCSI Adapters
- (4.) You should see the item HPT366 Ultra DMA Controller (started) listed

### 3. Partitioning Your Hard Disk

If the hard disk drive attached to the HPT366 host adapter has not been partitioned and formatted yet, you need to partition it first. To partition the hard disk drive attached to the HPT366 host adapter, follow the following steps:

- (1.) Click the Startup button
- (2.) Go to Administrative Tools (Common)
- (3.) Run Disk Administrator
- (4.) Select disk number you would like to partition
- (5.) Select the menu Partition
- (6.) Decide the partition size create partition of the size
- (7.) Exit Disk Administrator
- (8.) Select the new created partition (logical disk drive) and format it

### 4. Troubleshooting

The boot manager for Windows NT contains recovery logic to allow you to return to the last known good

configuration. If you have changed your host adapter configuration and Windows NT no longer boots, follow these steps to recover:

1. Undo any hardware changes you have made to the computer since it was last operational.
2. Reboot the computer. Watch the display carefully during booting up. If the following message appears, press the Spacebar and follow the instructions on the display screen to continue booting with the last known good configuration: Press spacebar NOW to invoke the Last Known Good menu
3. Once your computer is operational again, check all of the hardware and software configuration changes you want to make. Look specially for conflicts with parts of the existing system configuration that are not being changed.

If Windows NT can boot but the driver has not been started (see Checking the Installation), please check the following:

1. Make sure the host adapter is properly installed, and the device is correctly connected to the adapter. Double check that the cable between the adapter and the devices is correctly attached. Also check if the jumper setting on the drive is correct.
2. Make sure that a power cable is properly attached to each drive attached to the HPT366 host adapter.

If the driver has started and you still cannot access the hard disk drive attached to the HPT366 host adapter, the hard disk drive might have not been partitioned and formatted yet. You may need to partition and format it.

### New Driver releases and Support

If you have questions about installing or using this HighPoint product, check this user's guide or the readme file first, you will find answers to most of your questions here. If you need further assistance, we offer the following support and information services:

1. The Web Site provides information on software upgrades, answers to common questions, and other topics. The Web Site is available from Internet 24 hours a day, 7 days a week, at <http://www.highpoint-tech.com>.
2. For technical support, send an e-mail to [support@highpoint-tech.com](mailto:support@highpoint-tech.com).

*NOTE: Before you send an e-mail, please visit our Web Site (<http://www.highpoint-tech.com>) to check if there is a new or updated HPT366 device driver for your operating system.*

## **SY-6BA+ IV Quick Start Guide**

---

### **How to contact us:**

- If you are interested in our products, please contact the SOYO sales department in the region you live.
- If you require Technical Assistance, please contact our Technical Support in the region you live.

SOYO prefers Email as communication medium, remember to *always add to the email the country that you live in.*

### **SOYO Taiwan**

---

No. 21 Wu-Kung 5 Rd., Hsin Chuang City, Taipei Hsien, Taiwan

Region Covered: Taiwan and Asia-Pacific. (Including Australia).

Web Site: [www.soyo.com.tw](http://www.soyo.com.tw)

#### *Sales:*

Tel: 886-2-22903300-318

Fax: 886-2-22983322

E-mail: [salesap@mail.soyo.com.tw](mailto:salesap@mail.soyo.com.tw)

#### *Technical Support:*

Fax: 886-2-22983322

E-mail: [support@mail.soyo.com.tw](mailto:support@mail.soyo.com.tw)

### **SOYO Europe BV**

---

Signaalrood 19, 2718 SH Zoetermeer The Netherlands

Region Covered: Europe except Germany, Austria and Switzerland

Web Site: [www.soyo.nl](http://www.soyo.nl), [www.soyo-europe.com](http://www.soyo-europe.com)

#### *Sales:*

Tel: +31-69-3637500

Fax: +31-79-3637575

Email: [sales@soyo.nl](mailto:sales@soyo.nl)

#### *Technical Support:*

Tel : +31-79-3637500

Fax: +31-79-3637575

Email: [support@soyo.nl](mailto:support@soyo.nl)

### **SOYO USA**

---

41484 Christy Street, Fremont, CA 94538

Region Covered: US and Canada

Web Site: [www.soyousa.com](http://www.soyousa.com),  
[www.soyo.com](http://www.soyo.com)

#### *Sales:*

Tel: 510-226-7696

Fax: 510-226-9218

Email : [sales@soyosua.com](mailto:sales@soyosua.com)

#### *Technical Support:*

Tel: 510-226-7696

Fax: 510-226-9218

Email : [support@soyousa.com](mailto:support@soyousa.com)

### **SOYO (U.K.) LTD.**

---

Unit 7, Alice Way, Hounslow Business Park,  
Hanworth Road, Hounslow, TW3 3UD

Region Covered: United Kingdom and Republic of Ireland

Web Site: [www.soyo.co.uk](http://www.soyo.co.uk)

#### *Sales:*

Tel : +44 (0)181 569 4111

Fax: +44 (0)181 569 4134

E-mail: [sales@soyo.co.uk](mailto:sales@soyo.co.uk)

#### *Technical Support:*

Tel : +44 (0)181 569 4111

Fax: +44 (0)181 569 4134

E-Mail: [support@soyo.co.uk](mailto:support@soyo.co.uk)

### **SOYO Deutschland GmbH**

---

August-Wilhelm-Kuhnholz-Str. 15  
D-26135 Oldenburg

---

Region Covered: Germany, Austria  
and Switzerland. (Zuständig für  
Deutschland, Österreich, Schweiz)

---

Web Site: [www.saat.de](http://www.saat.de), [www.soyo-saat.com](http://www.soyo-saat.com), [www.soyo-saat.de](http://www.soyo-saat.de)

---

Vertrieb Mainboards, Notebooks und  
SoyoCom Produkte:

E-Mail: [sales@soyo.de](mailto:sales@soyo.de)

Fon: +49-(0)441/20910-31/33

Fax: +49-(0)441/203422

*Technischer Support:*

E-Mail: [support@soyo.de](mailto:support@soyo.de)

Fon: +49-(0)441/20910-40

Fax: +49-(0)441/203422

### **SOYO KOREA**

---

Region Covered: Korea

---

*Sales:*

Tel : 82-2-716-2850

Fax : 82-2-704-2619

E-mail : [soyo@soyo.co.kr](mailto:soyo@soyo.co.kr)

*Technical Support:*

tel : 82-2-717-4392

fax : 82-2-712-5853

e-mail : [soyok@chollian.net](mailto:soyok@chollian.net)

### **SOYO Hong Kong**

---

Region Covered: Hong Kong

---

Web Site: [www.soyo.com.hk](http://www.soyo.com.hk)

*Sales:*

tel: 852-27109810

fax: 852-27109078

E-mail: [soyo@hkstar.com](mailto:soyo@hkstar.com)

*Technical Support:*

tel: 852-27109810

fax: 852-27109078

E-mail: [soyo@hkstar.com](mailto:soyo@hkstar.com)

### **SOYO China (Gin Mei Jei)**

---

Region Covered: All of China

---

*Sales:*

Tel: 86-10-62510089

fax: 86-10-62510388

E-mail: [soyo@public.bta.net.cn](mailto:soyo@public.bta.net.cn)

*Technical Support:*

Tel: 86-10-62510089

fax: 86-10-62510388

E-mail: [soyo@public.bta.net.cn](mailto:soyo@public.bta.net.cn)

### **SOYO Japan**

---

Region Covered: Japan

---

Web site: [www.soyo.co.jp](http://www.soyo.co.jp)

---

*Sales:*

Tel: 81-3-33682188

Fax: 81-3-33682199

E-mail: [soyo-jpn@soyo.co.jp](mailto:soyo-jpn@soyo.co.jp)

*Technical Support:*

Tel: 81-3-33682188

Fax: 81-3-33682199

E-mail: [support@soyo.co.jp](mailto:support@soyo.co.jp)

**Edition: December 1999**  
**Version 1.1**  
**SY-6BA+ IV**  
**SERIAL**

