

TABLE OF CONTENTS

1. INTRODUCTION

1.1. PREFACE..... 1-1

1.2. KEY FEATURES..... 1-1

1.3. PERFORMANCE LIST 1-2

1.4. BLOCK DIAGRAM 1-3

1.5. INTRODUCE THE Pentium® II Processor & AGP..... 1-4

1.6. What is AGP? 1-5

2. SPECIFICATION

2.1. HARDWARE 2-1

2.2. SOFTWARE 2-2

2.3. ENVIRONMENT..... 2-2

3. HARDWARE INSTALLATION

3.1. UNPACKING 3-1

3.2. MAINBOARD LAYOUT..... 3-2

3.3. QUICK REFERENCE FOR JUMPERS & CONNECTORS 3-2

3.4. DRAM INSTALLATION..... 3-6

3.5. CPU SPEED SETUP 3-7

3.6. CMOS RTC & ISA CFG CMOS SRAM 3-8

3.7. SPEAKER CONNECTOR INSTALLATION 3-8

3.8. HARDWARE RESET SWITCH CONNECTOR INSTALLATION 3-9

3.9. POWER LED CONNECTOR INSTALLATION 3-9

3.10. IDE & ATAPI DEVICE INSTALLATION 3-9

3.11. PERIPHERAL DEVICE INSTALLATION3-9

3.12. KEYBOARD & PS/2 MOUSE INSTALLATION.....3-9

4. BIOS CONFIGURATION

4.1. ENTERING SETUP4-1

4.2. CONTROL KEYS4-1

4.3. GETTING HELP4-2

 4.3.1. Main Menu4-2

 4.3.2. Status Page Setup Menu / Option Page Setup Menu.....4-2

4.4. THE MAIN MENU4-2

4.5. STANDARD CMOS SETUP MENU4-4

4.6. BIOS FEATURES SETUP4-8

4.7. CHIPSET FEATURES SETUP4-13

4.8. POWER MANAGEMENT SETUP4-17

4.9. PNP/PCI CONFIGURATION4-21

4.10. LOAD BIOS DEFAULTS.....4-23

4.11. LOAD PERFORMANCE DEFAULTS.....4-24

4.12. INTEGRATED PERIPHERALS4-25

4.13. SUPERVISOR/USER PASSWORD.....4-30

4.14. IDE HDD AUTO DETECTION.....4-31

4.15. SAVE & EXIT SETUP4-32

4.16. EXIT WITHOUT SAVING4-33

1. INTRODUCTION

1.1. PREFACE

Welcome to use the **6BXA** motherboard. It is a Pentium® II / Celeron Processor based PC / AT compatible system with AGP/ PCI / ISA Bus, and has been designed to be the fastest PC / AT system. There are some new features allow you to operate the system with just the performance you want.

This manual also explains how to install the motherboard for operation, and how to set up your CMOS CONFIGURATION with BIOS SETUP program.

1.2. KEY FEATURES

- ❑ Intel Pentium® II / Celeron Processor based PC / AT compatible mainboard.
- ❑ Slot 1 supports Pentium® II / Celeron processor running at 233-633 MHz.
- ❑ Intel 440BX chipset, Supports SDRAM / Ultra DMA 33 IDE.
- ❑ Built-in PCI **ESS SOLO 1** audio chip.
- ❑ Supports external Modem Ring-On on COM A&B and Internal.
- ❑ Supports Wake-up on LAN (JP10).
- ❑ Supports 3xDIMMs using 3.3V EDO or SDRAM DIMM module.
- ❑ Supports 16 MB - 768 MB SDRAM .
- ❑ 5xPCI Bus slots, 1xISA Bus slots, 1xAGP slot.
- ❑ Supports 2 channels Ultra DMA 33 IDE ports for 4 IDE Devices.
- ❑ Supports 2xCOM (16550), 1xLPT (EPP / ECP), 1x Floppy port.
- ❑ Supports 2xUSB ports, 1xPS/2 Mouse, 1xPS/2 Keyboard.
- ❑ Licensed AWARD BIOS, 2Mbits FLASH RAM.
- ❑ 30.5 cm x 19 cm ATX form factor, 4 layers PCB.

1.3. PERFORMANCE LIST

The following performance data list is the testing results of some popular benchmark testing programs.

These data are just referred by users, and there is no responsibility for different testing data values gotten by users. (The different Hardware & Software configuration will result in different benchmark testing results.)

- CPU Pentium® II processor
- DRAM (128 x 1) MB SDRAM (TOSHIBA TC59S6408FTL-80H)
- CACHE SIZE 512 KB included in CPU
- DISPLAY GA-630 voodoo banshee (16MB SGRAM)
- STORAGE Onboard IDE (IBM DHEA 36481)
- O.S. Windows NT™4.0 SPK4
- DRIVER Display Driver at 1024 x 768 x 64K colors x 75Hz.
TRIONES Bus Master IDE Driver 3.70a

Processor	Intel Pentium® II	
	500MHz(100x5)	400MHz(100x4)
Winbench99		
CPU mark32	1270	1080
FPU Winmark	2560	2070
Business Disk	4200	4070
Hi-End Disk	8210	8300
Business Graphics	228	198
Hi-End Graphics	408	345
Winstone99		
Business	34.2	31.3
Hi-End	30.2	26.7

1.4. BLOCK DIAGRAM

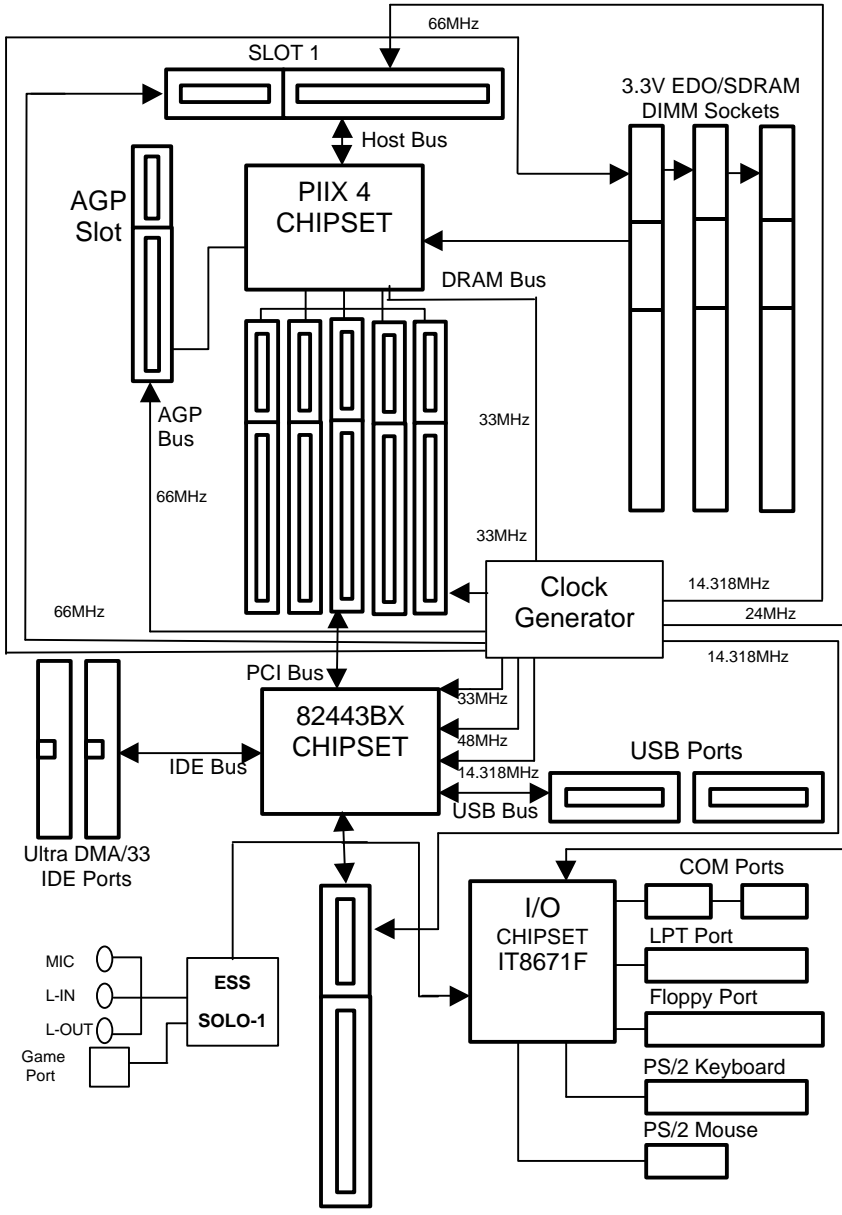

1.5. INTRODUCE THE Pentium® II Processor & AGP



Figure 1:Retention Mechanism & attach Mount



Figure 2:OEM Pentium® II Processor

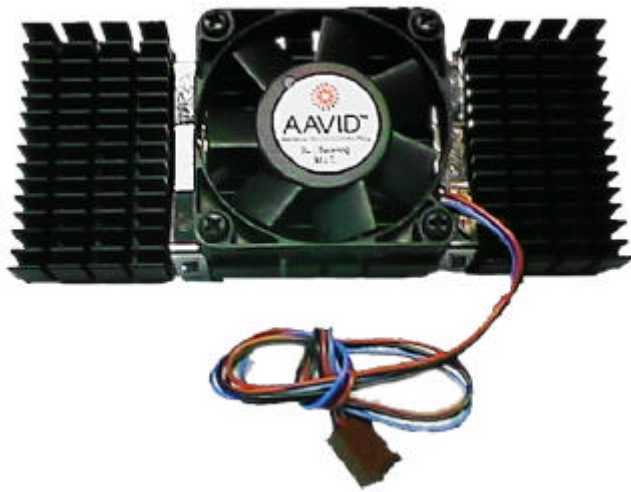

Figure 3:Heatsink / FAN & Heat sink support for OEM Pentium® II Processor

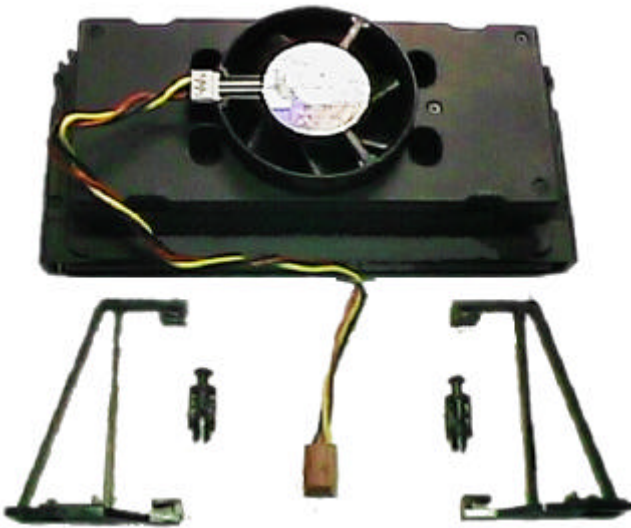

Figure 4:Boxed Pentium® II Processor & Heat sink support

1.6 What is AGP?

The Accelerated Graphics Port (AGP) is a new port on the Host-To-PCI bridge device that supports an AGP port. The main purpose of the AGP port is to provide fast access to system memory.

The AGP port can be used either as fast PCI port (32-bits at 66MHz vs. 32-bits at 33MHz) or as an AGP port which supports 2x data-rate, a read queue, and side band addressing. When the 2x-data rate is used, the port can transmit data at 533MB/sec ($66.6 \times 2 \times 4$). The read-queue can be used to pipeline reads – removing the effects of the reads-latency. Side band addressing can be used to transmit the data address on a separate line in order to speed up the transaction.

2. SPECIFICATION

2.1. HARDWARE

- CPU
 - Pentium® II / Celeron processor 233 – 633 MHz.
 - 242 pins 66 MHz slot1 on board.
- SPEED
 - 66/100 MHz system speed.
 - 66 MHz AGP bus speed. (2X mode 133MHz)
 - 33 MHz PCI-Bus speed.
 - 8 MHz AT bus speed.
- PROTECTION
 - Speaker Alarm when detect "CPU FAN Failure" or "CPU Overheat".
 - Automatically slow down CPU speed when "CPU Overheat".
 - H/W monitor power status ($\pm 5V$, $\pm 12V$, V_{COREA}, V_{GT}L, V_{CC3}, V_{BAT}, 5V_{SB} voltage & CMOS battery voltage).(Optional)
- DRAM MEMORY
 - 3 banks 168 pins DIMM module sockets on board.
 - Use 16 / 32 / 64 / 128 / 256 MB DIMM module DRAM.
 - 16 ~ 768MB SDRAM.
 - Supports 3.3V SDRAM / EDO type DRAM.
- CACHE MEMORY
 - 32 KB 1st cache memory included in CPU.
 - 256KB/512 KB 2nd cache in CPU.
 - Supports DIB speed mode for L2 Cache.
- I/O BUS SLOTS
 - 5 33MHz Master / Slave PCI-BUS.
 - 1 33MHz AGP BUS.
 - 1 8MHz 16 bits ISA BUS.
- IDE PORTS
 - 2 Ultra DMA 33 Bus Master IDE channels on board.(Using IRQ14,15)
 - Support Mode 3,4 IDE & ATAPI CD – ROM.
- Audio Ports
 - 1x Line in
 - 1x Line out
 - 1x Micro in
 - 1x Game Port
 - 2x CD Line in
 - 1x TEL Port

- I/O PORTS
 - Supports 2 16550 COM ports.
 - Supports 1 LPT port.
 - Supports 1 Floppy port.
 - Supports 2 USB ports.
 - Supports 1 PS/2 Mouse.
 - Supports 1 PS/2 Keyboard.
- GREEN FUNCTION
 - Suspend mode support.
 - Green switch & Green LED support.
 - IDE & Display power down support.
 - Monitor all IRQ / DMA / Display / I/O events.
- BIOS
 - 2M bits FLASH RAM.
 - Supports Plug & Play, DMI Function.
- DIMENSION
 - ATX Form Factor, 4 layers PCB.

2.2. SOFTWARE

- DRIVER
 - Bus Master IDE Driver.
 - INTEL Patch_95 Driver.
 - ESS SOLO-1 Sound Driver.
- BIOS
 - Licensed AWARD BIOS.
 - AT CMOS Setup, BIOS / Chipset Setup, Green Setup, Hard Disk Utility included.
- O.S.
 - Operation with MS-DOS®, Windows®95, Windows®98, WINDOWS™ NT, OS/2, NOVELL and SCO UNIX.

2.3. ENVIRONMENT

- Ambient Temp.
 - 0°C to +50°C (Operating).
- Relative Hum.
 - 0 to +85% (Operating).
- Altitude
 - 0 to 10,000 feet (Operating).
- Vibration
 - 0 to 1,000 Hz.
- Electricity
 - 4.9 V to 5.2 V. (Max. 20A current at 5V.)

3. HARDWARE INSTALLATION

3.1. UNPACKING

The mainboard package should contain the following:

- The **6BXA** mainboard.
- The Retention Mechanism & Attach Mount
- USER'S MANUAL for mainboard.
- Cable set for IDE, Floppy devices.
- CD or diskette for Mainboard; **Bound** and VGA Utility.

The mainboard contains sensitive electric components, which can be easily damaged by static electricity, so the mainboard should be left in its original packing until it is installed.

Unpacking and installation should be done on a grounded anti-static mat. The operator should be wearing an anti static wristband, grounded at the same point as the anti-static mat.

Inspect the mainboard carton for obvious damage. Shipping and handling may cause damage to your board. Be sure there are no shipping and handling damages on the board before proceeding.

After opening the mainboard carton, extract the system board and place it only on a grounded anti-static surface component side up. Again inspect the board for damage. Press down on all of the socket IC's to make sure that they are properly seated. Do this only on with the board placed on a firm flat surface.

⚠ DO NOT APPLY POWER TO THE BOARD IF IT HAS BEEN DAMAGED.

◆ JP4 : System Acceleration	
Pin No	Function
1-2 short	For 100MHz Turbo and other frequencies
2-3 short	For 100MHz Normal

◆ J3:CPU FAN (CPU cooling FAN Power Connector)	
Pin No.	Function
1	GND.
2	+12V
3	Signal

◆ JP10 : Wake on Lan	
Pin No.	Function
1	+5V SB
2	GND
3	Signal

◆ J2 : PWR FAN (Power Fan Connector)	
Pin No.	Function
1	GND
2	+12V
3	Signal

◆ J9: PANEL(SYS) FAN Connector	
Pin No.	Function
1	GND.
2	+12V
3	Signal

◆ J12 : ATX Power Control Selection	
Pin No.	Function
Open	Soft off.
Short	Full on.

◆ JP12 : RING Power On	
Pin No.	Function
1	Signal.
2	GND.

◆ JP13 : Clear CMOS	
Pin No.	Function
1-2 Short	Clear CMOS.
2-3 Short	NORMAL.

◆ JP18 / JP19 : Onboard Sound Function Selection	
Pin No.	Function
1-2 Close	Onboard Sound Function Enabled.
2-3 Close	Onboard Sound function Disabled.

◆ JP17 : Onboard Sound Function Selection	
Pin No.	Function
1.2 & 3.4 Open	Onboard Sound Function Enabled.
1.2 & 3.4 Close	Onboard Sound function Disabled.

◆ JP1 : Keyboard Power On Selection	
Pin No.	Function
1-2 Close	Enabled Keyboard power on.
2-3 Close	Disabled Keyboard power on.

◆ JP11 : CASE OPEN (Optional)	
Pin No.	Function
1	Signal
2	GND

◆ IR: INFRARED Connector (OPTIONAL)	
Pin No.	Function
1	IR Data Output
2	GND
3	IR Data Input
4	NC
5	POWER (+)

◆ JP14: Suspend To RAM Function (Optional)	
Pin No.	Function
Short	Enabled Suspend To RAM Function
Open	Normal Operation

◆ JP16: PCI Bus Freq.Select (133MHz only)	
Pin No.	Function
Open	133MHz PCI 33MHz
Close	133MHz PCI 44MHz

◆ JP20 : TEL:The Connector is for Modem with internal Voice connector	
Pin No.	Function
1	Signal
2	GND
3	GND
4	Signal

◆ SB-LINK : For PCI Audio / Sound Card use only (Optional)	
Pin No.	Function
1	Signal
2	GND
3	NC
4	Signal
5	GND
6	Signal

◆ CN6 : CD Audio Line In	
Pin	Function
1	GND
2	Right
3	GND
4	Left

◆ JP7 : CD Audio Line In	
Pin	Function
1	Right
2	GND
3	GND
4	Left

JP5 : For 2X11 PINs Jumper

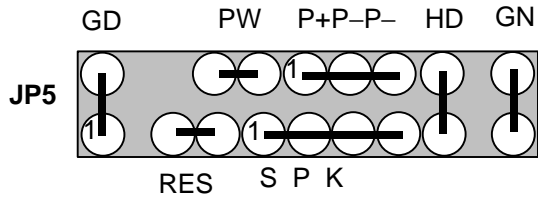

PW: Soft Power Connector



Open: Normal Operation
Short: Power On/Off

RES: Reset Switch

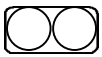

Open: Normal Operation
Short: For Hardware Reset System

P+P- P- : Power LED



PIN 1 : anode (+)
PIN 2 : cathode (-)
PIN 3 : cathode (-)

SPK: Speaker Connector

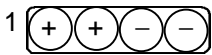

PIN 1 : VCC
PIN 2 : VCC
PIN 3 : Data
PIN 4 : Data

HD: IDE Hard Disk Active LED



PIN 1: LED anode (+)
PIN 2: LED cathode (-)

GN: Green Function Switch



Open : Normal operation
Short : Entering Green Mode

GD: Green LED

PIN 1 : LED anode (+)
PIN 2 : LED cathode (-)

3.4. DRAM INSTALLATION

The mainboard can be installed with 16 / 32 / 64 / 128 / 256 MB 168 pins DIMM module DRAM, and the DRAM speed must be 50 or 60 ns for EDO & 67~100 MHz for SDRAM. The DRAM memory system on mainboard consists of bank 0 ,bank 1& bank 2.

Since 168 pins DIMM module is 64 bits width, using 1 PCS which can match a 64 bits system. The total memory size is 16MB ~ 768MB SDRAM. The DRAM installation position refer to Figure 3.1, and notice the Pin 1 of DIMM module must match with the Pin 1 of DIMM socket. Insert the DRAM DIMM module into the DIMM socket at Vertical angle. If there is a wrong direction of Pin 1, the DRAM DIMM module couldn't be inserted into socket completely.

3.5. CPU SPEED SETUP

The default system bus speed is 66/100MHz. The user can change the DIP SWITCH (**SW2**) selection to set up the CPU speed for 233 - 633MHz processor. The CPU speed must match with the frequency RATIO. It will cause system hanging up if the frequency RATIO is higher than CPU's.

SW1:

CPU	AGP	PCICLK	1	2	3	4
66	66	33.4	ON	OFF	OFF	ON
75	75	37.5	ON	ON	OFF	ON
83	86	41.65	ON	OFF	ON	ON
100	66	33.43	OFF	OFF	OFF	OFF
112	75	37.33	OFF	ON	OFF	OFF
133	89	44.33	OFF	OFF	ON	OFF

SW2:

CLK RATIO	1	2	3	4
X3	ON	OFF	ON	ON
X3.5	OFF	OFF	ON	ON
X4	ON	ON	OFF	ON
X4.5	OFF	ON	OFF	ON
X5	ON	OFF	OFF	ON
X5.5	OFF	OFF	OFF	ON
X6	ON	ON	ON	OFF
X6.5	OFF	ON	ON	OFF

- The CPU is a sensitive electric component and it can be easily damaged by static electricity, so users must keep it away from metal surface when the CPU is installed onto mainboard.
- Note: We don't recommend you to setup your system speed to 75, 83, 112 or 133MHz because these frequencies are not the standard specifications for CPU, Chipset and most of the peripherals. Whether your system can run under 75, 83, 112 or 133MHz properly will depend on your hardware configurations: CPU, SDRAM, Cards, etc.

3.6. CMOS RTC & ISA CFG CMOS SRAM

The mainboard contains RTC & CMOS SRAM on board. They have a power supply from external battery to keep the DATA inviolate & effective. The RTC is a REAL-TIME CLOCK device, which provides the DATE & TIME to system. The CMOS SRAM is used for keeping the information of system configuration, so the system can automatically boot OS every time. Since the lifetime of internal battery is 5 years, the user can change a new Battery to replace old one when it has consumed.

3.7. SPEAKER CONNECTOR INSTALLATION

There is a speaker in AT system for sound purpose. The 4 - Pins connector **SPK** is used to connect speaker.

3.8. HARDWARE RESET SWITCH CONNECTOR INSTALLATION

The RESET switch on panel provides users with HARDWARE RESET function. The system will do a cold start after the RESET switch is press and released by user. The RESET switch is a 2 PINS connector and should be installed to **RES** on mainboard.

3.9. POWER LED CONNECTOR INSTALLATION

System has power LED lamp on the panel of case. The power LED will light on off or flash to indicate which step on the system. The connector should be connected to **LED** of mainboard in correct direction.

3.10. IDE & ATAPI DEVICE INSTALLATION

There are two-Enhanced PCI IDE ports (**IDE1, IDE2**) on board, which following ATAPI standard SPEC. Any one IDE port can connected to two ATAPI devices (IDE Hard Disk, CD-ROM & Tape Driver), so total four ATAPI devices can exist in a system. The **HD** is the active LED port for ATAPI devices.

3.11. PERIPHERAL DEVICE INSTALLATION

After the I/O device installation and jumpers setup, the mainboard can be mounted into the case and fixed by screw. To complete the mainboard installation, the peripheral device could be installed now. The basic system needs a display interface card. If the PCI - Bus device is to be installed in the system, any one of four PCI - Bus slots can be used.

3.12.PS/2 KEYBOARD & MOUSE INSTALLATION

The main board supports PS/2 Mouse. The BIOS will auto detect whether the PS/2 Mouse is installed or not & assign IRQ12 for PS/2 Mouse port if it is installed. After installing the peripheral device, the user should check everything again, and prepare to power-on the system.

